

02 - 05.5

10.05.GB

**Control valves, starting
G 93 ...**



Kv coefficient calculation

Calculation itself is carried out with respect to conditions of regulating circuit and operating medium according to equations mentioned below. Control valve must be designed to be able to regulate maximal flow quantity at given operating conditions. At the same time it is necessary to check whether minimal flow quantity can be even regulated or not.

Because of eventual minus tolerance 10% of Kv_{100} against Kvs and requirement for possible regulation within range of maximal flow (decrement and increase of flow), producer recommends to select Kvs value higher than maximal operating Kv value:

$$Kvs = 1.2 \div 1.3 Kv$$

It is necessary to take into account to which extent Q_{max} involve "precautionary additions" that could result in valve oversizing.

Relations of Kv calculation

		Pressure drop $p_2 > p_1/2$ $\Delta p < p_1/2$	Pressure drop $\Delta p \geq p_1/2$ $p_2 \leq p_1/2$
Kv =	Liquid	$\frac{Q}{100} \sqrt{\frac{\rho_1}{\Delta p}}$	
	Gas	$\frac{Q_n}{5141} \sqrt{\frac{\rho_n \cdot T_1}{\Delta p \cdot p_2}}$	$\frac{2 \cdot Q_m}{5141 \cdot p_1} \sqrt{\rho_n \cdot T_1}$
	Superh. steam	$\frac{Q_m}{100} \sqrt{\frac{v_2}{\Delta p}}$	$\frac{Q_m}{100} \sqrt{\frac{2v}{p_1}}$
	Sat. steam	$\frac{Q_m}{100} \sqrt{\frac{v_2 \cdot x}{\Delta p}}$	$\frac{Q_m}{100} \sqrt{\frac{2v \cdot x}{p_1}}$

Above critical flow of vapours and gases

When pressure ratio is above critical ($p_1/p_2 < 0.54$), speed of flow reaches acoustic velocity at the narrowest section. This event can cause higher level of noisiness.

Cavitation

Cavitation is a phenomenon when there are steam bubbles creating and vanishing in shocks - generally at the narrowest section of flowing due to local pressure drop. This event expressively cuts down service life of inner parts and can result in creation of unpleasant vibrations and noisiness. In control valves it can happen on condition that

$$(p_1 - p_2) \geq 0.6 (p_1 - p_s)$$

Valve differential pressure should be set the way so that neither any undesired pressure drop causing cavitation can occur, nor liquid-steam(wet steam) mixture can create. Otherwise it must be taken into account when calculating Kv value.

Valve flow characteristic

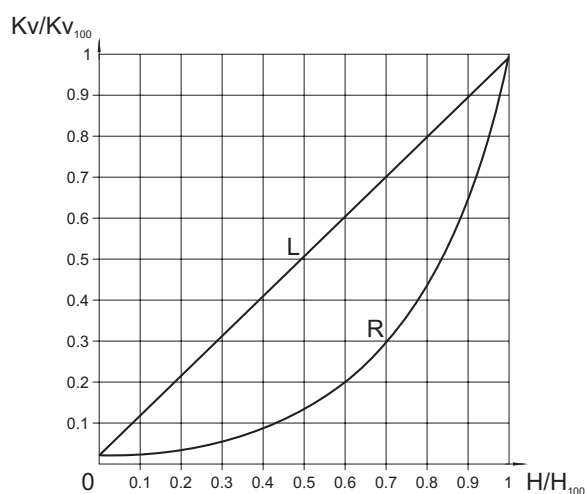

- L - linear charakteristic
R - equal-percentage characteristic (4-percentage)
 $Kv/Kv_{100} = 0.0183 \cdot e^{(4 \cdot H/H_{100})}$

Dimensions and units

Marking	Unit	Name of dimension
Kv	m ³ /hour	Flow coefficient under conditions of units of flow
Kv_{100}	m ³ /hour	Flow coefficient at nominal stroke
Kvs	m ³ /hour	Valve nominal flow coefficient
Q	m ³ /hour	Flow rate in operating conditions (T_1, p_1)
Q_n	Nm ³ /hour	Flow rate in normal conditions (0°C, 0.101 MPa)
Q_m	kg/hour	Flow rate in operating conditions (T_1, p_1)
p_1	MPa	Upstream absolute pressure
p_2	MPa	Downstream absolute pressure
p_s	MPa	Absolute pressure of saturated steam at given temperature (T_1)
Δp	MPa	Valve differential pressure ($\Delta p = p_1 - p_2$)
ρ_1	kg/m ³	Process medium density in operating conditions (T_1, p_1)
ρ_n	kg/Nm ³	Gas density in normal conditions (0°C, 0.101 MPa)
v_2	m ³ /kg	Specific volume of steam when temperature T_1 and pressure p_2
v	m ³ /kg	Specific volume of steam when temperature T_1 and pressure $p_1/2$
T_1	K	Absolute temperature at valve inlet ($T_1 = 273 + t_1$)
x	1	Proportionate weight volume of saturated steam in wet steam

Diagram for the valve Kvs value specification according to the required flow rate of water Q and the valve differential pressure Δp

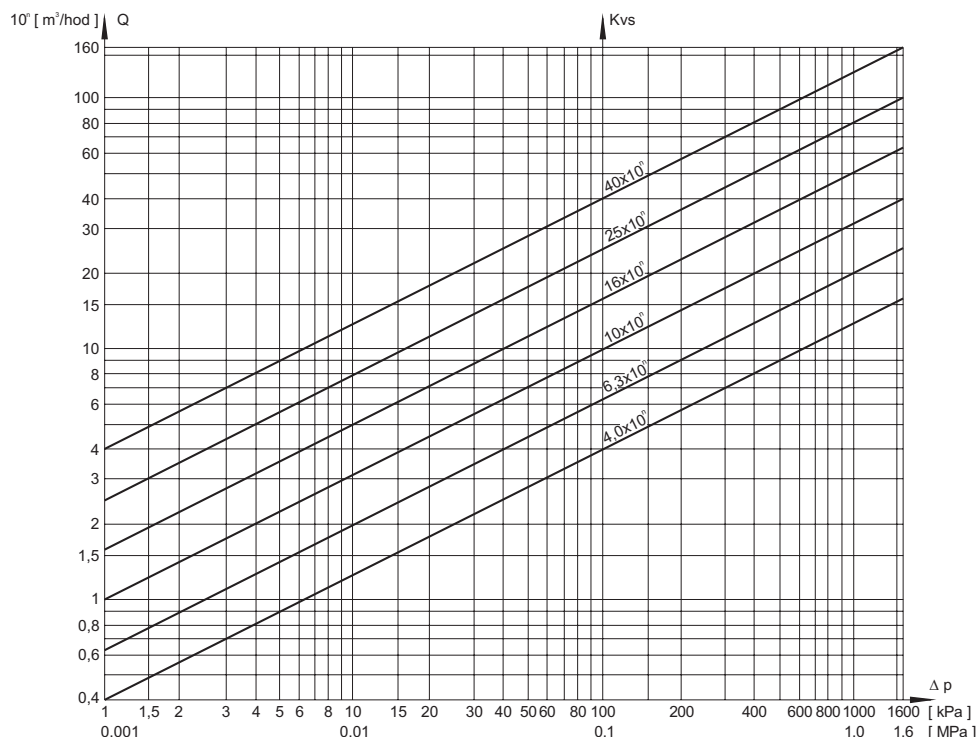

The diagram serves to specify the valve Kvs value regarding to the required flow rate of water at a given differential pressure. It can be also used for finding out the differential pressure value of the existing valve in behaviour with the flow rate. The diagram applies to water with the density of 1000 kg/m³.

For the value $Q = q \cdot 10^n$, it is necessary to calculate with $Kvs = k \cdot 10^n$. Example: water flow rate of $16 \cdot 10^{-1} = 1,6 \text{ m}^3/\text{hour}$ corresponds to $Kv = 2,5 = 25 \cdot 10$ when differential pressure 40kPa.

Valve complete specification No. for ordering G 93

		X XX	X X X	- X XXX	/ XXX	- XXX
1. Valve	Control valve	G				
2. Series	Control valve, starting	93				
3. Flow direction	Angle		2			
4. Connection	Weld ends		2			
5. Actuating	Adjusted for remote control		5			
6. Material	Alloy steel 1.7357			2		
7. Nominal pressure PN	Acc. to the valve execution				XXX	
8. Max. operating temp.°C	Acc. to the valve execution					XXX
9. Nominal size DN	Acc. to the valve execution					XXX

Maximal permissible pressures acc. to EN 12 516-1 [MPa]

Material	PN	Temperature [°C]							
		200	250	300	350	400	450	500	550
Alloy steel 1.7357	400	37.4	35.7	33.3	30.9	28.9	26.7	22.3	8.8



G 93 225 2400

Control valve, starting DN 150, PN 400

Description

The valve is single-seated, angle, welding ends. Control mechanism with a multi-stage pressure reduction is made by special control cage with holes and cross section grooves and two plugs. Main piston plug, which is a part of the valve stem, provides media flow control and ensures also a tightness when the valve is closed. Internal perforated plug reduces the pressure drop at stroke begins to prevent wear of sealing surfaces. Valve is equipped by a Chesterton stuffing box, type "Live Loading". Valve is designed to be actuated with an electric rotating actuator ZPA Pečky, type Modact MO, eventually by Auma or Schiebel actuators.

Application

The valves serves as a control valve applicable to where it is necessary to change the flow water pressure from its maximum value to minimum or vice versa. The max. operating pressures correspond to EN 12 516-1 see page 3 of this catalogue. The possible use for higher temperature must be agreed upon with the producer.

Process media

The valve is designed to control the flow and pressure of water and steam. The valve max. differential pressure is 20,0 MPa with respect to the concrete conditions of operation (ratio p_1 / p_2 , creation of cavitation, above critical flow etc.)

Installation

The valve can be installed only in a vertical position with the nut for the connection to the actuator being positioned up above the valve body. The valve should be piped the way so that the medium flow coincides with the arrows indicated on the valve body. With regard to the valve's dismantling, it is recommended to leave a clear space of up to 500 mm above the valve for easy approach. For safe operation, it is necessary so that there would be no bends or elbows piped at least 2000 mm behind the valve.

Technical data

Series	G 93 225 2400	
Type of valve	Control valve (starting), weld ends, angle	
Nominal size	150	
Nominal pressure	400	
Body material	Alloy steel 1.7357	
Weld ends material	Alloy steel 1.7335	
Process media temp. range	-20 to 550°C	
Connection *	ČSN 13 1070	
Type of trim	Special cage - piston type plug + internal perforated plug Multi-step reduction	
Průtočná charakteristika	Linear	Equal-percentage
Flow area F_s [cm ²]	30	63
Kvs values [m ³ /h]	60	190
Leakage rate	Class II acc. to ČSN EN 1349 (5/2001)	
Packing	Grafit - Live Loading	

*) After the agreement with the producer, it is possible to make the connection acc. to the valid ČSN 13 1075 (3/1991) or ČSN EN 12 627 (8/2000)

Dimensions and weights for G 93 225 2400

Weight of the valve is 630 kg

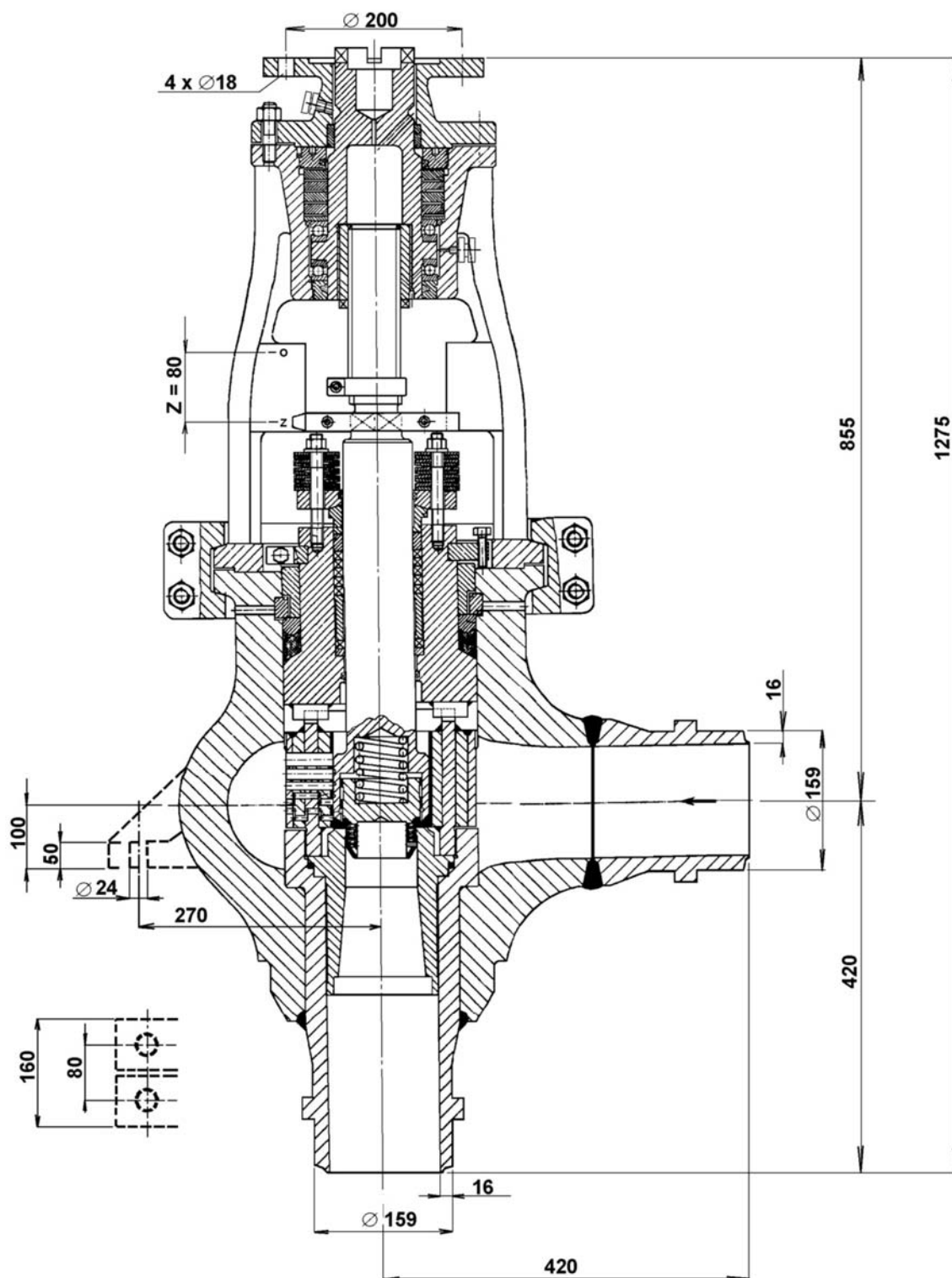



Electric actuators SAR 16.1 Auma

Technical data

Type	SAR 16.1
Voltage	400 V
Frequency	50 Hz
Motor power	See specification table
Control	3 - position control or with signal 4 - 20 mA
Nominal torque	500 - 1000 Nm
Stroke	See specification table
Enclosure	IP 67
Process medium max. temperature	Acc. to used valve
Ambient temperature range	-25 to 60°C
Ambient humidity limit	100 %
Weight	75 - 86 kg

Specification of Auma actuators

Type		SA	X	XX.X
Function	control	SA	R	
Actuator size	16.1			16.1

Output shaft type C - flange F16

Output speed (rpm)	Tripping torque	SAR 16.1	
		500-1000 Nm	Motor power [kW]
4			0,75
5,6			0,75
8			1,50
11			1,50
16			3,00
22			3,00
32			5,50
45			5,50

Accessories

2 TANDEM switches

Gearing for signalisation of position

Mechanical position indicator

Potentiometer 1x200 Ω

Electronic position transmitter RWG (potentiometer included), 4 - 20 mA, 2-wire

Electronic position transmitter RWG (potentiometer included), 4 - 20 mA, 3/4-wire

Inductive position transmitter IWG, 4 - 20 mA

AUMATIC - for continuous control (specification of accessories acc. to catalogue of producer)

AUMA MATIC - for continuous control (specification of accessories acc. to catalogue of producer)

Dimensions of actuators Auma

Normal execution

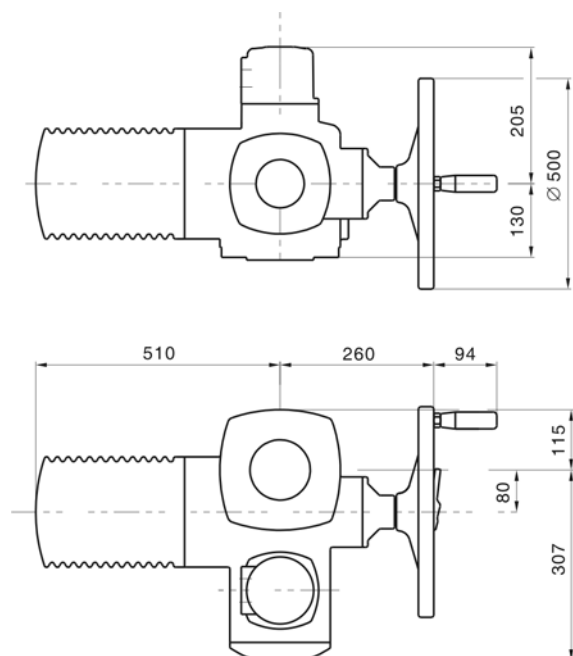

Execution AUMATIC

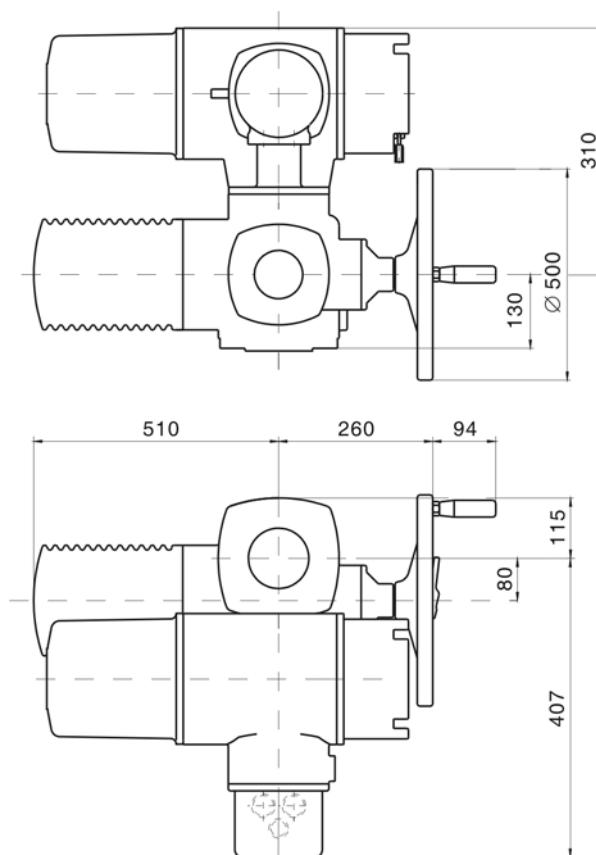

Execution AUMA MATIC

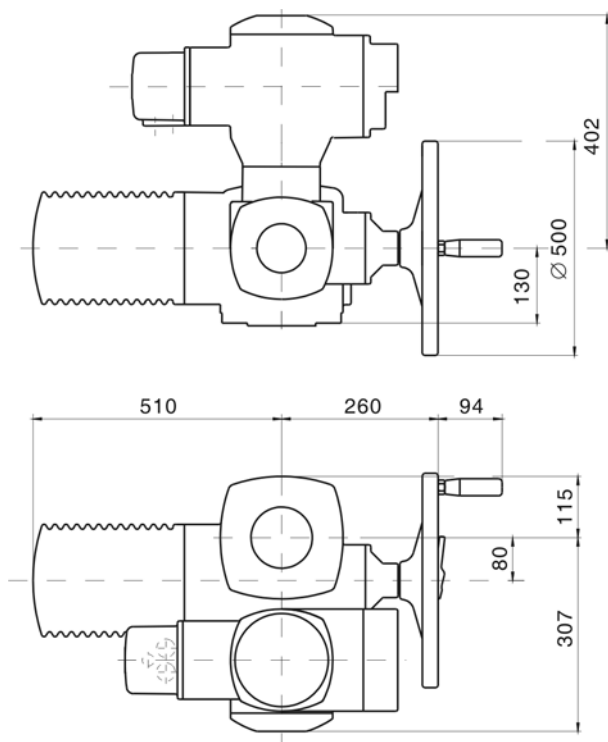

Output shaft C

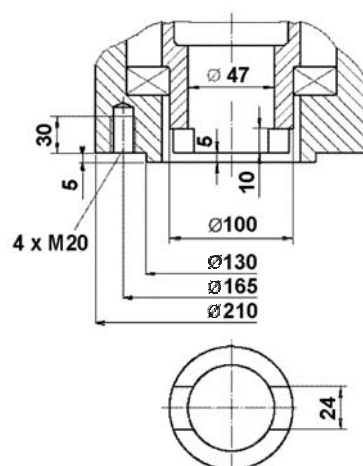



Electric actuators Modact MON and Modact MON Control ZPA Pečky

Technické parametry

Type	52 034 MON	52 034 MON Control
Voltage	3x 230/400 V	
Frequency	50 Hz	
Motor power	See specification table	
Control	3 - position control or continuous	
Nominal power	320 - 630 Nm	
Resetting speed	See specification table	
Enclosure	IP 55	
Process medium max. temperature	Acc. to used valve	
Ambient temperature range	Acc. to ČSN 33 2000-3, classes AA7, AB7, AC1, AD5, AE5, AF2, AG2, AH2, Ak2, AL2, AM2, AN2, AP3, BA4, BC3	
Working condition	loading S2 acc. to ČSN EN 60 034-1	
Weight	100 kg	

Rozměry pohonů

DIMENSIONAL DRAWING OF ACTUATORS MODACT MON

52 034 EXECUTION WITH TERMINAL BOARD

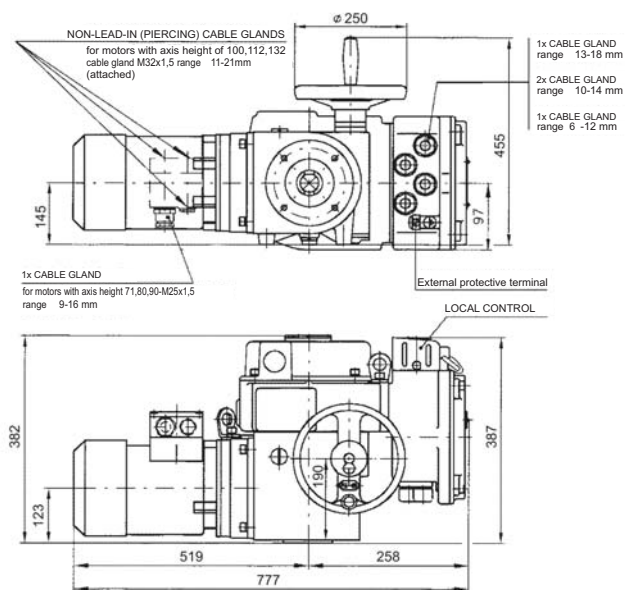

DIMENSIONAL DRAWING OF ACTUATORS MODACT MON

52 034 EXECUTION WITH CONECTOR

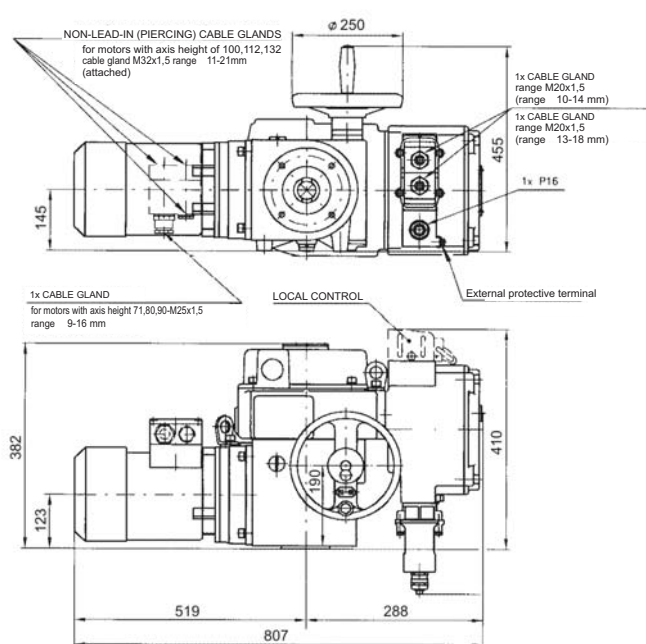

DIMENSIONAL DRAWING OF ACTUATORS MODACT MON CONTROL

Output shaft type C

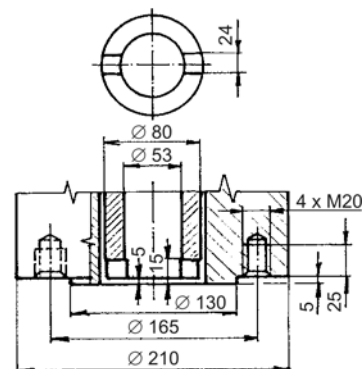
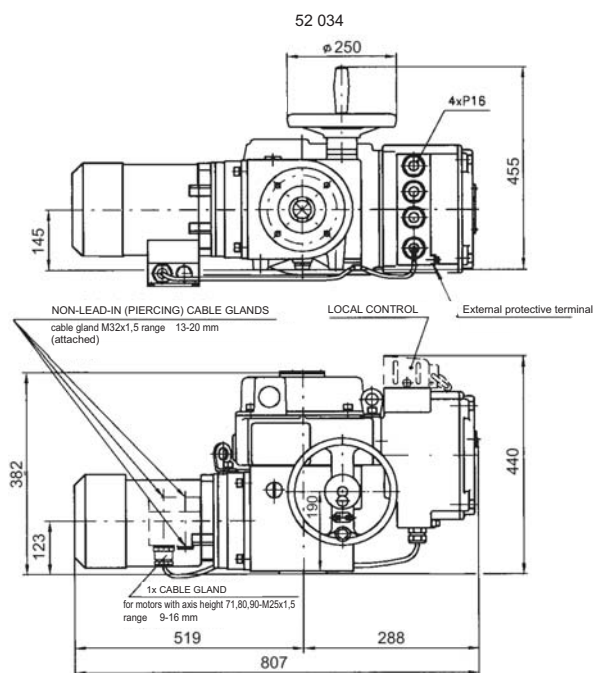

Specification of actuator Modact MON

				XX XXX	X	X	X	X	X	
Connection dimensions	Output shaft type C	Via terminal board			7					
		With connector			H					
Local control, position indicator										
Resistance transmitter or execution without transmitter		Without local control, without position indicator			1					
		Local control			2					
		Local control for actuators Modact MON Control			4					
		Local control and position indicator			6					
		Local control for Modact MON Control			7					
		Local control and position indicator for Modact MON Control			8					
Capacity transmitter CPT 1/A		Without local control, without position indicator			B					
		Local control			E					
		Local control for actuators Modact MON Control			H					
Type marking	Moment		Running speed	Operation stroke	Electromotor				52 034	
	Tripping	Driving			Power	RPM	I_n (400V)	I_z / I_n		
	(Nm)	(Nm)	(1/min.)	(ot)	(kW)	(1/min.)	(A)	(-)		
MON630/900-16	320÷630	900	16	2÷240	1,50	705	3,90	3,7		0
MON630/835-20		835	20		1,50	925	3,90	4,2		1
MON630/945-35		945	35		2,20	1420	4,70	5,5		2
MON630/1000-63		1000	63		4,00	1440	8,20	6,5	3	
Signalization, position transmitter, blinker										
Only for actuators Modact MOP	Without signalisation, position transmitter and blinker								0	
	Position transmitter								1	
	Signalization switches								2	
	Signalization switches and position transmitter								3	
	Blinker								4	
	Position transmitter, blinker								5	
	Signalization switches and blinker								6	
	Signalization switches, position transmitter, blinker								7	

The table continues on next page



Continuation of the table of the specification of Modact MOP from the previous page

			XX XXX	X	X	X	X	X	
Signalization, position transmitter, blinker									
Only for actuators Modact MOP Control	Complete equipment Sch P-0781	Position transmitter						A	
		Signalization switches and position transmitter						B	
		Position transmitter, blinker						C	
	Without positioner	Signalization switches, position transmitter and blinker							D
		Without signalization, without posit. transmitter and blinker							E
		Position transmitter							F
		Signalization switches							G
		Signalization switches and position transmitter							H
		Blinker							I
		Position transmitter, blinker							J
	Without positioner and brake BAM	Signalization switches, blinker							K
		Signalization switches, position transmitter and blinker							L
		Without signalization, without position transm. and blinker							M
		Position transmitter							N
		Signalization switches							O
		Signalization switches and position transmitter							P
		Blinker							R
		Position transmitter, blinker							S
This mark is valid for the the types of the actuators	Signalization switches, blinker							T	
	Signalization switches, position transmitter and blinker							U	
								N	



LDM, spol. s r.o.
Litomyšlská 1378
560 02 Česká Třebová
Czech Republic

tel.: +420 465 502 511
fax: +420 465 533 101
E-mail: sale@ldm.cz
<http://www.ldm.cz>

LDM, spol. s r.o.
Office in Prague
Podolská 50
147 01 Praha 4
Czech Republic

tel.: +420 241 087 360
fax: +420 241 087 192

LDM, spol. s r.o.
Office in Ústí nad Labem
Mezní 4.
400 11 Ústí nad Labem
Czech Republic

tel.: +420 475 650 260
fax: +420 475 650 263

LDM servis, spol. s r.o.
Litomyšlská 1378
560 02 Česká Třebová
Czech Republic

tel.: +420 465 502 411-3
fax: +420 465 531 010
E-mail: servis@ldm.cz

LDM, Polska Sp. z o.o.
Modelarska 12
40 142 Katowice
Poland

tel.: +48 32 730 56 33
fax: +48 32 730 52 33
mobile: +48 601 354 999
E-mail: ldmpolska@ldm.cz

LDM Bratislava s.r.o.
Mierová 151
821 05 Bratislava
Slovakia

tel.: +421 2 43415027-8
fax: +421 2 43415029
E-mail: ldm@ldm.sk
<http://www.ldm.sk>

LDM - Bulgaria - OOD
z. k. Mladost 1
bl. 42, floor 12, app. 57
1784 Sofia
Bulgaria

tel.: +359 2 9746311
fax: +359 2 9746311
GSM: +359 888 925 766
E-mail: ldm.bg@stark-net.net

OOO "LDM Promarmatura"
Moskovskaya street,
h. 21, Office No. 520
141400 Khimki
Russian Federation

tel.: +7 495 777 22 38
fax: +7 495 777 22 38
E-mail: inforus@ldmvalves.com

TOO "LDM"
Lobody 46/2
Office No. 4
100008 Karaganda
Kazakhstan

tel.: +7 7212 566 936
fax: +7 7212 566 936
mobile: +7 701 738 36 79
E-mail: sale@ldm.kz
<http://www.ldm.kz>

LDM Armaturen GmbH
Wupperweg 21
D-51789 Lindlar
Germany

tel.: +49 2266 440333
fax: +49 2266 440372
mobile: +49 177 2960469
E-mail: ldmarmaturen@ldmvalves.com
<http://www.ldmvalves.com>

Your partner