

 LDM, spol. s r.o. Czech Republic	INSTRUCTIONS FOR INSTALLATION AND SERVICE	PV 1509
	SAFETY VALVE according to EN ISO 4126-5	

The instructions for installation, operation and maintenance of safety valves PV1509 are binding for users to ensure proper function of valves. The user must keep the below written rules during the lifetime period of valve. Technical details of individual execution are specified in catalogue data sheets.

If the usage of the valves is different from mentioned herein, the guarantee terms are not valid any more.

1. TECHNICAL DESCRIPTION AND FUNCTION OF VALVE

1.1 Description

The valve has angle type body, with possibility of welded, flanged or combined (inlet welded, outlet flanged) type of pipe connection. The inlet part is shaped as nozzle, the outlet gradually increases its flow area. There are two pins, welded to valve body, which can be used for fixing of valve to supporting frame and bearing the reaction force.

The force of spring and the force of pneumatic cylinder put the disc back to the seat. The bottom of disc has additional area, which increases the force of media when valve starts to open. There is double piston, moving inside of air cylinder, the pressure air from control unit is feed over (loading air) and under (lifting air) it.

The opening pressure p_{set} (CDTP) is set in manufacturing facility, to value specified in order/mutually agreed. This setting is sealed.

The dimensions of flanges or weld ends are agreed between manufacturer and customer. Standard weld connection is according to EN 12627, standard flange connection s according to EN 1092-1+A1.

1.2 Application

The safety valve is determined for protection of pressure equipment (boilers, pipelines, steam conditioning stations, pressure vessels, etc.) against excessive pressure.

The safety valve type PV 1509, controlled by the control unit type RP 5330, respectively RP 5340 conforms to requirements EN ISO 4126-5 (CSPRS).

The relieving capacity, stated in documentation and valve's ID plate, is guaranteed in case of inlet pipeline pressure loss $\leq 3\%$ of p_{set} and outlet backpressure $\leq 25\%$ of P_{set} .

1.3 Technical data

The safety valve PV 1509 is determined for steam, air and non-aggressive gases and vapors. The highest temperature of medium is 600°C, the range of ambient temperature for continuous operation of valve is from 0°C to 80°C. After consulting with producer, the valves can be installed (and operated) in areas with ambient temperature below 0°C.

The opening pressure range see table below.

The valve is delivered and must be operated together with the control unit. As the single part, the PV can be used only in case of replacement of previously delivered equipment.

Valve size DN	Seat		Opening pressure		Certified de-rated coefficient of discharge $K_{dr} [-]$
	d [mm]	A [mm ²]	p_{set} [barg]		
			minimal	maximal	
65 x 100	40	1257	160	250	0,84
	46	1662	135	250	
80 x 125	50	1963	122	250	
	56	2463	100	250	
100 x 150	63	3117	90	250	
	70	3848	77	250	
125 x 200	77	4657	72	250	
	85	5675	63	250	
150 x 250	93	6793	54	250	
	98	7543	45	250	
175 x 300	110	9503	38	100	
	117	10751	34	100	
200 x 350	125	12272	29	85	
	140	15394	24	85	
250 x 400	155	18869	20	80	
	168	22167	16	70	
300 x 500	180	25447	13	75	
	200	31416	11	75	
350 x 500 (600)	220	38013	10	62,5	0,83
	235	43374	9	55	

Material of main parts

Position	Name	Material			
		400	550	575	600
	T_{max} [°C]	400	550	575	600
1.1	Body	1.0619	1.7357	1.7379	1.4931
1.2	Inlet nozzle + seat facing	1.0426 + Stellite 6	1.7335 + Stellite 6	1.7380 + Stellite 6 1.7383 + Stellite 6	1.4901 + Stellite 6 1.4903 + Stellite 6
1.3	Outlet extension	1.0426	1.7335	1.7380 1.7383	1.4901 1.4903
2	Bonnet	1.0425	1.7335	1.7380	1.4903
3	Disc + seat facing	1.4923 + Stellite 6 / 1.4922 + Stellite 6			1.4901 + Stellite 6 1.4903 + Stellite 6
5	Disc guide	42 2942.4 / 1.4541			1.4923
6	Spindle	1.4122			1.4903/1.4923
7	Belleville spring	1.8159			
10	Cylinder	1.7357			
11	Piston	11 523 / 1.0570			
12	Weld connection	1.0425	1.7335		1.4903

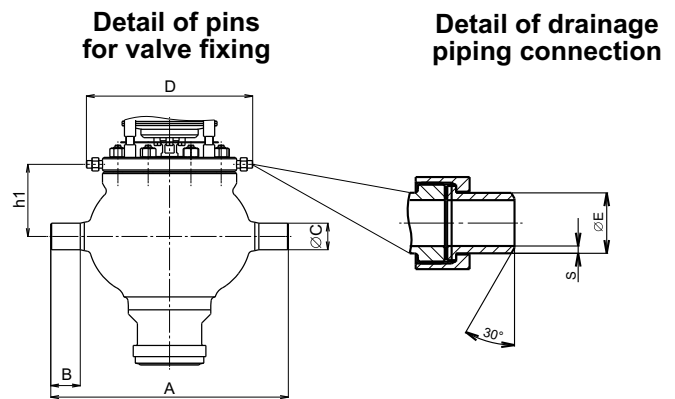
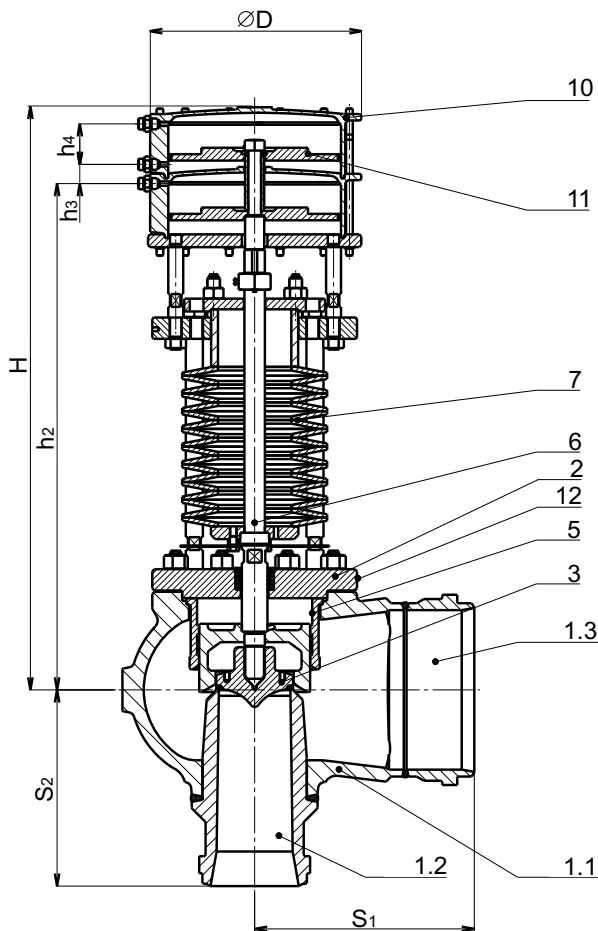

Dimensions and weights

DN	A	B	ØC	D	ØE	S	h1
65x100	415	75	51	354	26,9	3,2	110
80x125	440	90	60	354	26,9	3,2	120
100x150	520	90	63,5	464	26,9	3,2	145
125x200	530	90	63,5	464	26,9	3,2	161
150x250	610	90	63,5	520	26,9	3,2	198
175x300	700	100	95	520	26,9	3,2	213
200x350	750	100	95	594	26,9	3,2	218
250x400	850	100	95	594	26,9	3,2	258
300x500	950	130	127	680	26,9	3,2	308
350x600	1150	160	135	680	26,9	3,2	333

DN	h ₂	h ₃	h ₄	H	D	S ₁	S ₂	Weight
	mm	mm	mm	mm	mm	mm	mm	kg
65x100	760	45	55	890	290	275	240	170
80x125	760	45	55	890	290	290	265	190
100x150	850	45	65	995	395	310	270	380
125x200	940	45	65	1085	395	390	330	480
150x250	1050	45	95	1260	500	390	350	650
175x300	1065	45	95	1275	500	420	390	670
200x350	1080	45	95	1290	500	440	420	780
250x400	1160	45	95	1370	500	515	460	980
300x500	1250	45	125	1460	500	590	530	1560
350x600	1400	45	125	1610	500	660	620	1900

Note: Weight, stated in the table, is valid for the valve with weld connection.

Tolerance $\pm 10\%$, based on pset (used Belleville spring).

Dimensions H, h₂ are variable ± 100 mm, based on pset (used Belleville spring).

2. CONDITION OF VALVE WHEN DELIVERED

- the state of the valve/valve's packing shall be inspected immediately after delivery
- the data on ID plate shall be checked and compared with the data in the order and accompanying documents
- the valve is delivered with following documents: safety valve certificate, test report in form of 3.1 atest according to EN 10204, material certificates (body, inlet nozzle, outlet extension, disc, disc guide, spindle, bonnet, bolts and nuts), certificate of quality and completeness, diagram of safety valve to control unit connection, drawing of connection ends and this instruction. The scope of documents can be modified according to customer's demand.
- the opening pressure P_{set} (CDTP) is set in manufacturing facility, to value specified in order. Inspection or re-setting of P_{set} is done on installed valve at standard operating condition of protected device

2.1 PV1509 ID plate

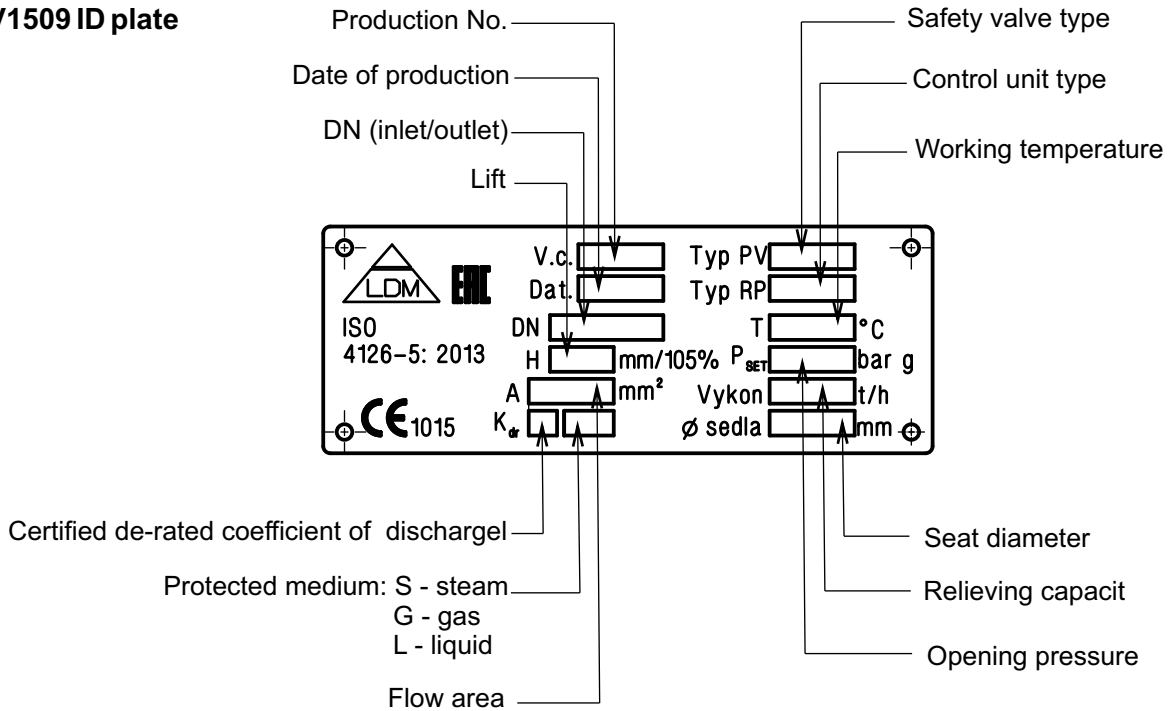

2.2 PV1509 sealing

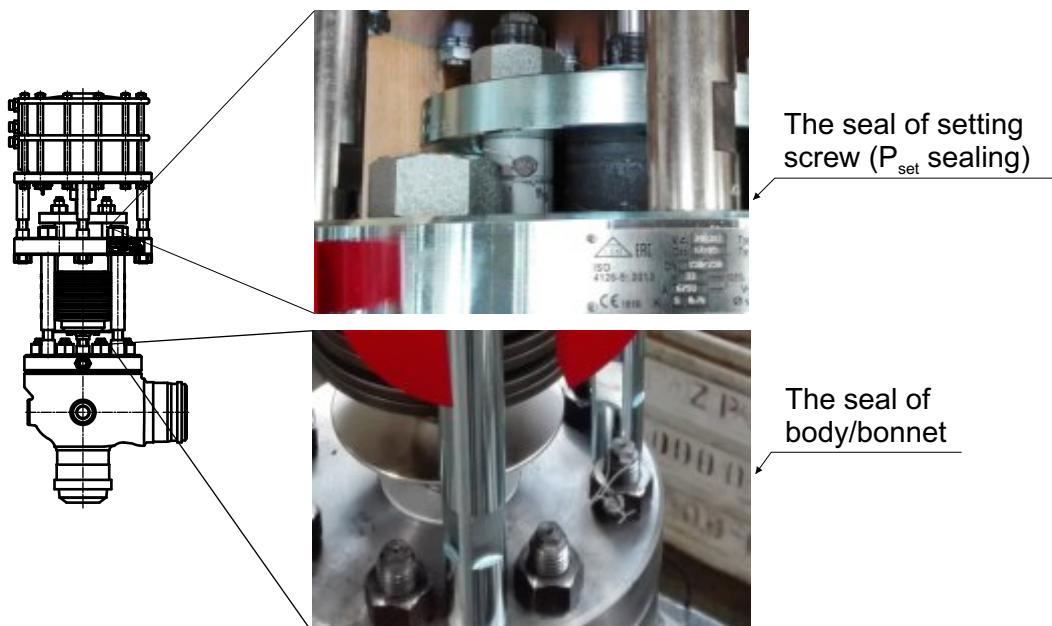

2.3 Transport and storage

The valve shall be protected against the water/rain during the transport and storage, maximum relative humidity shall be less than 75%. The temperature shall be in range -20°C to 80°C.

The valve is delivered on wooden frame, protecting grease is applied on the weld ends respective the flanges. The inlet and outlet ports are blinded. The whole valve is wrapped in the special protecting foil (containing rust inhibitors).

The valve shall be stored in this original packing, at the IB type store (under the roof).

For the manipulation with the valve, the suitable fixing and fastening means, e.g. harness, shall be used. The harness shall be fixed to 2 air cylinder columns. 2 lifting lugs, outer thread M12 (for DN65x100- DN80x125) respectively M20 (for DN100x150-DN350x600), threaded into air cylinder can be used eventually.

The expert deep inspection of the valve prior it's installation is recommended in case, it is stored for more than 3 years.

Usage of lifting harness during manipulation

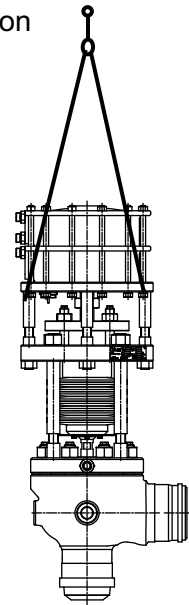

3. VALVE INSTALLATION

3.1 Following rules/recommendations shall be observed during the project phase

- valve ambient temperature must be less than 80°C
- the spindle shall be in the vertical position.
- easy access to valve for maintenance purposes and also free and easy movement around the valve in case of emergency must be arranged.
- beam/lug for the lifting device hanging must be placed above the valve. For the weight of the valve, see the table on page 2.
- access to the inlet flange connection must be kept in mind, when the supporting frame is used for PP version of the valve. The decision about usage of supporting frame is the responsibility of protected device designer, based on valve's weight, reaction forces and stiffness/strength of pipeline.
- the body must be insulated up to the plane 30 mm below the body/ bonnet connection (plane X – X, see picture page 9).
- the bonnet, spring and air cylinder must not be insulated
- the control unit (RP5330, RP5340) is an integral part of the safety valve. Instructions for control unit installation, operation and maintenance are issued separately.
- the distance (length of pressure air pipeline) between the safety valve and the control unit should not exceed 15m.

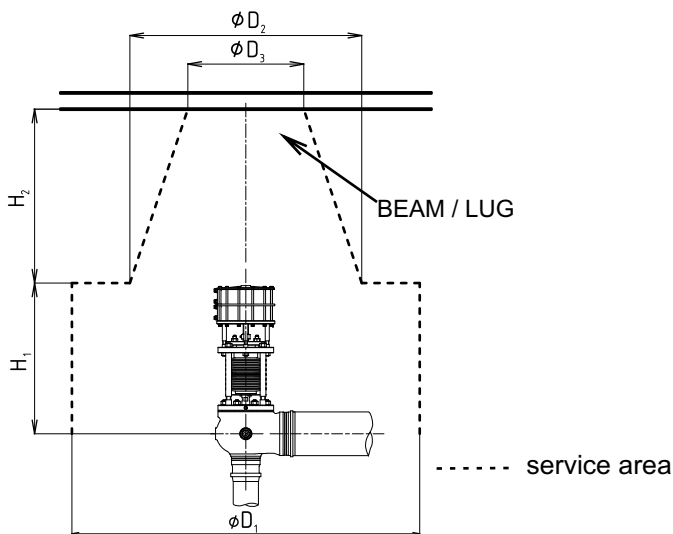

	D1	D2	D3	H1	H2
	[mm]	[mm]	[mm]	[mm]	[mm]
DN 65x100 - 125x200	2000	1000	1000	1000	1500
DN 150x250 - 250x400	3000	2000	1000	1300	1500
DN 300x500 - 350x600	3000	2000	1000	1700	1500



INLET PIPELINE

- shall be as short and as straight as possible. Thermal dilatation must be kept in mind.
- shall be self-draining, i.e. to prevent condensate accumulation inside.
- shall be designed to withstand the forces of reaction when the valve opens.
- no restriction/closing device may be installed in it.
- no other outlet/pressure taking over from inlet pipeline between the main steam line/protected device and safety valve is allowed.
- flow area of inlet pipeline should not be smaller than the flow area of the safety valve inlet nozzle.
- in case of actual relieving capacity (certified capacity + 10%) the pressure loss of pipeline shall be no more than 3% of P_{set} .
- shall be insulated.
- shall be connected properly to prevent water taking up, in case the safety valve is connected directly to boiler's drum
- shall be warmed to the temperature of protected medium in case of long pipeline and high temperature of protected medium

DISCHARGE PIPELINE

- flow area of discharge pipeline should not be smaller than the largest flow area of the valve outlet extension.
- flow area of collective discharge pipeline should not be smaller than 125% of sum of all individual pipelines.
- total backpressure of the discharge pipeline (for actual relieving capacity) including the backpressure of the silencer or superimposed backpressure, shall be less than 25% of P_{set} .
- connection for the pressure gauge shall be placed as close to the safety valve as possible.
- no closing device may be installed in the pipeline.
- the pipeline, including the suspension/support shall be designed to withstand the forces of reaction when the valve opens.
- the pipeline must first slope down from the valve.
- the drainage must be done in the lowest point of discharge pipeline, to prevent clogging by dirt or the possibility of freezing. Drainage must be free of restrictions and the end of it must be visible and accessible for possible cleaning.

PIPELINE FOR DRAINAGE OF STEAM FROM THE SPACE ABOVE THE DISC

- the pipeline must be vented to the atmosphere (to the sink), the end must be visible (to check the function) and accessible for cleaning.

3.2 Required steps prior to safety valve installation

- the inlet pipeline shall be chemically cleaned and blown through. Otherwise, the valve seat can be damaged or the valve closing restricted by particles/objects, resulting in valve disassembly.
- the valve should be carefully checked. It must not be installed if any damage is found.
- protective covers and plugs should not be removed until immediately prior to the installation, to protect the valve against infiltration of dirt and objects
- the ID plate data (serial number, KKS code, etc.) should be checked/compared with order/project data
- the seals of setting screw and seals of body/bonnet connection shall not be broken (2 + 1 pieces).

4. CONNECTION OF VALVE TO CONTROL UNIT

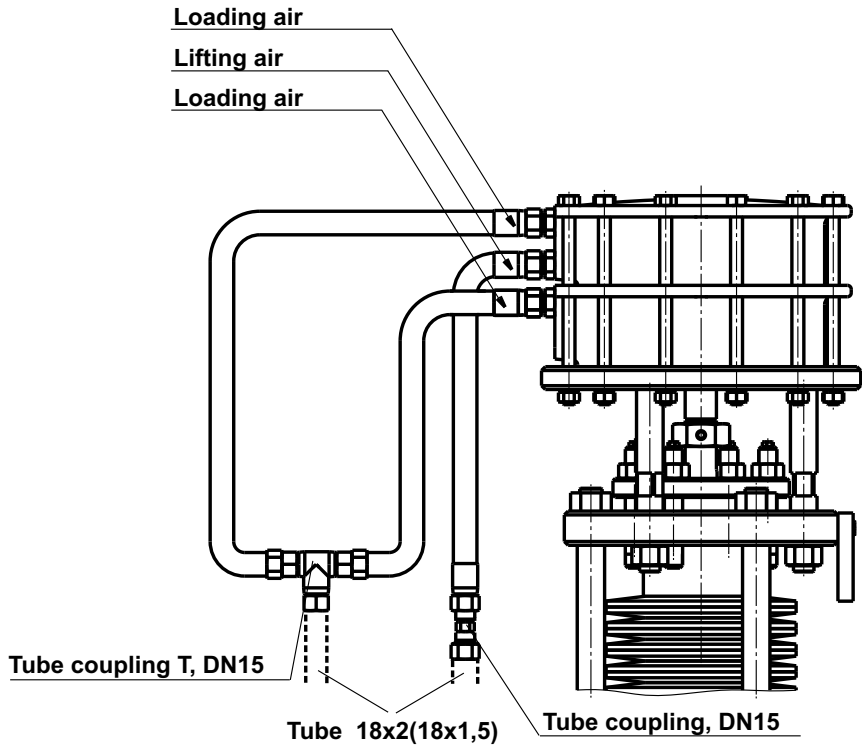

- Parts of delivery:
- 3x High-pressure hose DN15
 - 1x Tube coupling, DIN2353, DN 15
 - 1x Tube coupling T, DIN2353, DN 15

The pressure air pipeline is not part of the delivery.

The correct dimension of tubes should be used (18x2, 18x1,5). Recommended material of tube - steel 1.7362 (X11CrMo5), 1.7386 (X11CrMo9-1), 1.4903 (X10CrMoVNb9-1) or 1.4922 (X20CrMoV11-1). The ends must be flat, round and smooth, to accept the sealing ring (ermeto). Recommended painting of the whole pipeline (or its ends, at least): **green – loading air, blue – lifting air**. The same color is used on the valve and control unit pipe connections. It eliminates possible confusion during the valve connection.

Pressure hoses, delivered with the valve must be used for connection of pressure air pipeline to valve. It is not permissible to use any other type of connection.

5. LIFT INDICATION (OPTION)

- Inductive sensor TURCK, type Bi5-S18-VP4X/S100 - operational voltage 10-65 VDC
 - operational current 200mA
 - degree of protection IP67

- The sensor is fixed to safety valve and adjusted.
- There must be a signal light in the control room for each valve equipped with lift indication.
- The manufacturer retains the right to change the type of sensor used.



Inductive sensor – wiring diagram:

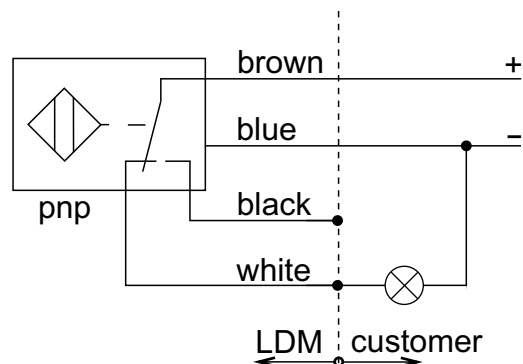

safety valve closed - the signal lamp is OFF
 safety valve open - the signal lamp is ON

6. HYDROSTATIC PRESSURE TEST OF PROTECTED EQUIPMENT

The gag iron is used to hold the safety valve closed, if the test pressure exceeds the set pressure of valve. For this reason, each PV1509 safety valve is equipped with it. The red color painted gag iron, normally placed on the upper flange of yoke, shall be placed above the gag iron nut. Subsequently this nut shall be tightened against the bottom of air cylinder. The right value of tightening torque see table below.

Location of gag iron during the routine operation



Gag iron

Location of gag iron during the hydro- static pressure test

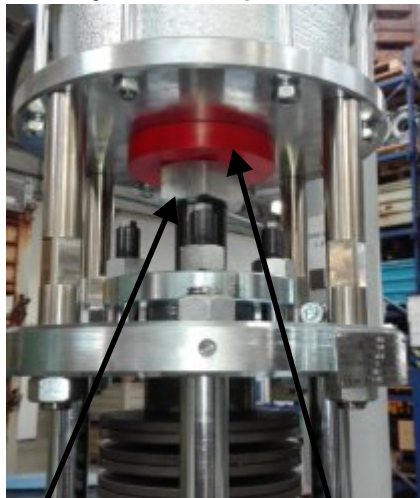

Gag iron

The gag iron nut used to keep the spring pressed for safety valve disassembly (body/bonnet)



Gag iron nut

The gag iron shall be removed (located back to the upper flange of yoke) and the control unit shall be put into operation when the pressure test is finished.

Table of test pressure accumulation ΔP_{ZK1} and ΔP_{ZK2} over the value of P_{set} and value of tightening torque Mu

PV 1509 size	ΔP_{ZK1} [bar]	ΔP_{ZK2} [bar]	Wrench size 6HR	Mu [Nm]
DN 65x100 D40	243	431	65	250
DN 65x100 D46	188	333		
DN 80x125 D50	158	281		
DN 80x125 D56	128	228	65	300
DN 100x150 D63	120	277		
DN 100x150 D70	99	228		
DN 125x200 D77	82	189	75	400
DN 125x200 D85	68	157		
DN 150x250 D93	67	200		
DN 150x250 D98	61	181	75	400
DN 175x300 D110	48	143		
DN 175x300 D117	43	128		
DN 200x350 D125	38	113	85	500
DN 200x350 D140	30	91		
DN 250x400 D155	25	74		
DN 250x400 D168	21	63	85	500
DN 300x500 D180	19	55		
DN 300x500 D200	16	46		
DN 350x600 D220	14	39	85	500
DN 350x600 D235	12	34		

The valve held closed by gag iron:

- calculation of maximum value of test pressure:

$$P_{ZK} = P_{set} + \Delta P_{ZK1}$$

- the gag iron nut shall be tightened to the tightening torque according the table

- the control unit shall be switched off (pressure air supply broken) during the pressure test

The valve held closed by gag iron + loading air:

- calculation of maximum value of test pressure:

$$P_{ZK} = P_{set} + \Delta P_{ZK2}$$

- control unit is used for increasing the closing force

- the lifting air shall be released

- the loading air (4 barg) shall be applied as the 1st, than the gag iron nut can be tightened to torque according the table.

- above mentioned operation can be done by experience personnel (LDM Servis staff) only.

If there is demand for the test pressure even higher, than the maximum value calculated according the formulas above, the valve shall be split (body/bonnet) and the special tools shall be used for disc closing. The spring is kept pressed by using of gag iron nut. The other possibility is to remove the valve from it's position and inlet pipe shall be blinded.

The strength of inlet pipeline (weld/flange) connection shall be recalculated/checked in this case too.

7. COMMISSIONING

Commissioning is performed by LDM service Company, or by another company authorized by the manufacturer. In this case, the warranty is 3 years from the date of commissioning, or 4 years from the date of expedition. If the valve is commissioned by a non authorized company, the warranty is shortened to 3 years from the date of expedition.

The safety valve shall be operated together with its control unit only.

Commissioning and installation must be done carefully, to prevent possible complications and faults during valve operation. The commissioning can be divided into two stages:

7.1 Part executed prior to boiler/protected device start-up (without pressure of protected medium)

- inspection of the correct connection of the valve cylinder to the air piping: loading air (green pipeline) to the upper part of the cylinder, lifting air (blue pipeline) to the lower part of the cylinder. **The hoses must not be confused.**

- inspection of the valve fixing, inlet and discharge pipeline, pipeline for steam drainage, etc.

- test/setting of remote lift indicator.

7.2 Part executed after boiler/protected device start-up

As there is internal pressure in the inlet part of the safety valve, the rules for safe working must be observed.

- safety valve opening (remote control opening). No person may be near the safety valve.

- test/adjustment of set pressure (adjusting of safety valve's main spring).

- test of remote lift indicator.

- verification of seat tightness when above mentioned tests are carried out.

8. OPERATION AND TESTS

The safety valve must be protected against unauthorized manipulation and damage during the operation.

Also, the regular test of safety valve function must be performed. The recommended test period is 3 months.

The 3-way ball valves, placed inside the control unit, are used for test execution. In the regular operation state, the straight way of the loading air ball valve is open and compressed air is applied above the piston. If the straight way of ball valve is closed, the compressed air is released and the safety valve opens. This procedure is valid for the "N" connection. In case of "T" connection, the lifting air must be applied first, by opening the straight way of respective ball valve (for more, see the RP 5330/RP 5340 Control unit instruction manual). The loading air is applied again, and the valve closes by opening of straight way of loading air ball valve. The control unit must be set to original state after the test is finished.

The function of the safety valve can be tested by remote control too, directly from the control room. If two safety valves are controlled by one control unit, they can open both (depending on the type of connection N2 or NT)

To be able to perform the above described tests of function, at least 80% of P_{set} must be in the protected device in most cases. The test (and its result) must be recorded in the boiler/protected device log book.

The opening of the safety valves, caused by increasing of pressure over the value of P_{set} is considered as test of function too.

9. MAINTENANCE

9.1 Routine maintenance

No special maintenance is necessary. Only the regular weekly visual inspection of condition and cleanness of valve and pressure air hoses (loading and lifting air leakage) is required.

9.2 Trouble shooting

Trouble:

Safety valve does not close tightly.

Remedies:

- check the function of the Control unit
- check the pressure/tightness of loading air
- check the main spring adjustment
- disassemble the valve, check/rework the valve seat

Trouble:

Safety valve does not open at required set pressure.

Remedies:

- check the function of the Control unit
- check the main spring adjustment
- check the lifting and loading air pipeline for leaks.

Trouble:

Safety valve remains open – foreign body between seat and disc.

Remedies:

- open the valve (the same procedure as functional test). Medium surge may remove the object
- disassemble the valve in X - X plane, be careful to catch the object and thus prevent it from falling down into the inlet pipe. In the case of a valve with flange connection, the removal of the valve from the pipeline (plane Y – Y) prior to its disassembly is recommended. Another possibility is to disconnect the discharge pipeline first and catch the object before valve disassembly.

9.3 Inspection of safety valve, located on the steam boiler

9.3.1 Yearly inspection

Surface of seat/disc must be checked. The valve is disassembled in X – X plane. If necessary, the seat is regrinded/relapped on site. The disc can be reworked in the workshop too. Make sure no foreign object is allowed to fall into the valve/inlet pipeline.

Prior to disassembly, the main spring must be locked in its preloaded state. For this, the gag iron is used.

In the case of a badly damaged seat surface (some material/part of seat broken off, insufficient layer of hard facing), the repair procedure must be approved by the valve producer, the badly damaged disc is changed. The thickness of the hard-faced layer is cca 2 - 3 mm, which is enough for approximately 20 years of service life, providing the valve is maintained properly.

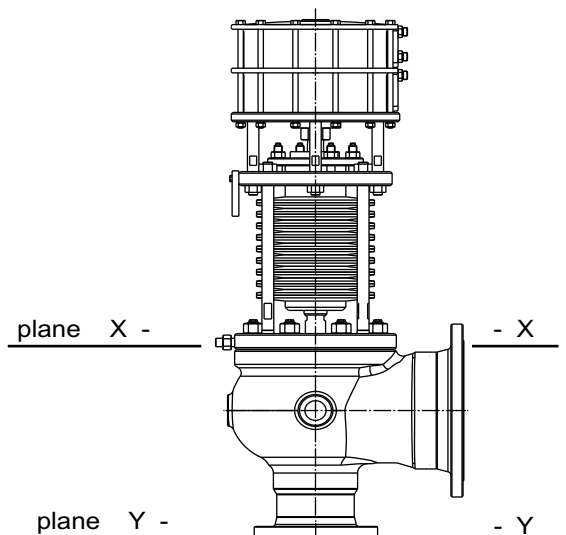

9.3.2 Tri-annual inspection

9.3.2.1 Safety valve

In addition to the regular yearly inspection of seat/disc, the air cylinder must be inspected. The air cylinder must be disassembled, checked, greased and the O-rings, if necessary, must be changed.

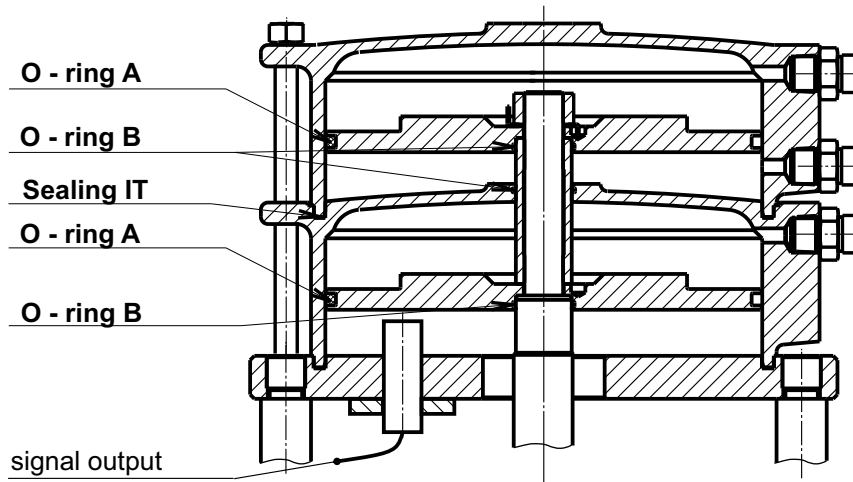

9.3.2.2 Pressure air piping

The whole pressure air piping between the safety valve and its control unit must be checked and possible leaks must be repaired. Also, the piping must be cleaned, dust and dirt removed/blown-off.

9.3.2.3 Safety valve spare parts for 3-year operation

- 1 pc disc
- 2 pcs O-ring A
- 3 pcs O-ring B
- 1 pc IT sealing (sealing of air cylinder)
- 3 pcs pressure air hose
- 1 pc graphite sealing (body - bonnet)

9.4. Inspection of the safety valve, located on devices other than steam boilers

The period of inspection of safety valves, located on devices such as reduction stations, feed water tanks, turbine by-passes, etc., can be extended, based on the real condition of the safety valve during the initial inspection and operational experience.

ATTENTION! The safety valve function and set pressure adjustment must be tested after each valve inspection.

10. WASTE DISPOSAL

The packaging material and the decommissioned safety valve shall be disposed in the common way, such as handling them over to the specialized waste management Compaq. The valve metal parts to metal waste, nonmetal parts including the packaging, flange avers ETA. to appropriate sort of municipal waste.

11. CONCLUSION

The safety valve works reliably and without defects, provided the above mentioned instructions are kept. You are recommended to ask the company LDM servis (contact see the last page) for valve commissioning, including the operator's training. LDM staff is well trained in all activities connected with valve commissioning and, based on their experience and knowledge of possible hazards, work strictly within all safety rules. The valve is sealed and a record is issued after each inspection/set pressure adjustment. This record should be part of boiler's/protected device's log book. All important data (ID number, dimension of valve, set pressure, height of adjusting spacers, etc.) are given in the protocol.

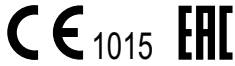

ADDRESS OF FACTORY

LDM, spol. s r.o.
Litomyšlská 1378
560 02 Česká Třebová
Czech Republic

tel.: +420 465 502 511
fax: +420 465 533 101
E-mail: sale@ldm.cz
<http://www.ldmvalves.com>

REGIONAL OFFICES

LDM, spol. s r.o.
Office in Prague
Podolská 50
147 01 Praha 4
Czech Republic

tel.: +420 241087360
fax: +420 241087192
E-mail: tomas.suchanek@ldm.cz

LDM, spol. s r.o.
Office in Ústí nad Labem
Ladova 2548/38
400 11 Ústí nad Labem - Severní Terasa
Czech Republic

tel.: +420 602708257
E-mail: tomas.kriz@ldm.cz

SERVICE ORGANIZATION

LDM servis, spol. s r.o.
Litomyšlská 1378
560 02 Česká Třebová
Czech Republic

tel: +420 465502411-13
fax: +420 465531010
E-mail: servis@ldm.cz

LDM SUBSIDIARIES ABROAD

OOO "LDM Promarmatura"
Jubilejnyi prospekt, dom.6a, of. 601
141407 Khimki
Moscow Region
Russia

tel.: +7 495 7772238
fax: +7 495 7772238
mobile: +7 9032254333
e-mail: inforus@ldmvalves.com

TOO "LDM"
Shakirova 33/1, kab. 103
100012 Karaganda
Kazachstan

tel.: +7 7212566936
fax: +7 7212566936
mobile: +7 7017383679
e-mail: sale@ldm.kz

LDM, Bratislava s.r.o.
Mierová 151
821 05 Bratislava
Slovakia

tel: +421 243415027-8
fax: +421 243415029
E-mail: ldm@ldm.sk
<http://www.ldm.sk>

LDM Armaturen GmbH
Wupperweg 21
D-51789 Lindlar
Deutschland

tel: +49 2266 440333
fax: +49 2266 440372
mobile: +49 1772960469
E-mail: ldmarmaturen@ldmvalves.com

LDM, Polska Sp. z o.o.
ul. Bednorza 1
40-384 Katowice
Polska

tel: +48 327305633
fax: +48 327305233
mobile: +48 601354999
E-mail: ldmpolska@ldm.cz

LDM Bulgaria Ltd.
z.k.Mladost 1
bl.42, floor 12, app.57
1784 Sofia
Bulgaria

tel: +359 2 9746311
fax: +359 2 8771344
mobile: +359 888925766
E-mail: ldm.bg@ldmvalves.com

www.ldmvalves.com

LDM, spol. s r.o. reserves the right to modify or improve the designs or specifications of such products at any time without notice
Guarantee and after guarantee service provided.