 LDM, spol. s r.o. Czech Republic	<b>INSTRUCTION FOR INSTALLATION AND MAINTENANCE</b>	<b>RS 702</b>
	<b>STEAM - CONDITIONING STATION</b>	PM - 084/17/10/GB

The instructions for installation and service of valves RS 702 are binding for users to ensure proper function of valves. The user must keep the rules said here while servicing, installation and using.

## 1. TECHNICAL DESCRIPTION AND VALVE FUNCTION

### 1.1 Description

Steam conditioning station RS 702 is single-seated control valve of a unit construction designed for water injection into the extended outlet. The pressure-balanced, multi-step throttling trim is designed to eliminate high differential pressures within the valve and ensure the low noisiness. It ensures a high resistance to wearing caused by medium flow and to effects of the expanding steam. Cooling water is injected into the extended outlet with a specially designed nozzle (VH or VHP) with changeable flow.

The valve is equipped with "LIVE LOADING" packing.

The valves can be supplied with weld ends.

The valves are actuated with linear electric actuators. The connection is designed for both domestic and foreign actuators of the following producers: ZPA Pečky, Regada, Přešov, AUMA, Schiebel and Flowserve.

### 1.2 Application

The valves are designed for simultaneous pressure and temperature reduction of steam. They are especially designed for industrial applications such as low-pressure steam production in heating, steam circuit in power plants or technological processes.

#### Recommended strainer dimensions:

For reliable function of the valves, the producer recommends to install the filter of mechanical impurities.

Installation of the filter is necessary for valve with micro-throttling system ( $Kvs \leq 0.16$ ).

DN, Type	Recommended maximum mesh size
DN 25, $Kvs \leq 0.16$	0,25 mm
DN 25-65	0,6 mm
DN 80-200	1,0 mm
DN 250	1,6 mm

The max. permissible operating pressure values correspond to EN 12 516-1.

### 1.3 Technical data

Series	RS 702		
Type of valve	Single-seated, control valves, straight-through, with pressure-balanced plug, with extended outlet and orifice plate in outlet and with injection of water into outlet pipeline		
Nominal diameter DN	Inlet DN 50-250, Outlet DN 150-700		
Nominal pressure PN	Inlet PN 160-320, Outlet PN 16-250	Inlet PN 160-400, Outlet PN 16-320	
Body material (including weld ends)	Cast steel - 1.0619	Alloy steel - 1.7357 Alloy steel - 1.7379	Stainless steel 1.4931
Weld ends material-extensions	1.0425 (1.0426)	1.7380, 1.7335, 1.7383	1.4922, 1.4923, 1.4903
Seat material	17 021.6 (1.4006), 42 2906.5 (1.4027) + overlay STELIT 6		
Plug material	17 023.6 (1.4078) hardened		17 021.6 (1.4006) + overlay STELIT 6
Operating temperature range	-10 to 400 °C	-10 to 550 °C	-10 to 600 °C
Weld ends	Acc.to ČSN 13 1075		
Control system	One or two-step pressure reduction Perforated plug - seat (cage), orifice plate		
Flow characteristic	Linear, equal - percentage		
Leakage rate	Acc. to ČSN EN 1349 - Class III, Execution with higher tightness - Class V		
Packing set	Graphite - "LIVE LOADING"		

### 1.3 Process media

The valves are designed to regulate the pressure and temperature of water vapour without mechanical impurities. The producer recommends to pipe a strainer into pipeline in front of the valve when impurities are present. Impurities can affect the quality and reliability of regulation and can cause a reduction of the valve service life. The application for other process media must be considered with respect to used material that is in contact with the process medium and therefore its usage should be consulted with the producer.

### 1.5 Recommended differential pressures

In regard to the pressure balancing of the plug and to linear forces of usable actuators, the valves' application in high differential pressures is not limited by the forces caused by process medium pressure but by the type of used throttling system. A recommended max. differential pressure for one step of multi-step pressure reduction is 5,0MPa when perforated plug and perforated cage are used. It is recommended to consult the concrete cases with the producer with regard to pressure ratio and parameters of other equipment.

### 1.6 Application of multi-step pressure reduction

For valves working with above-critical differential pressure ( $p_2/p_1 < 0.54$ ) or with pressure drop higher than recommended is useful to use two-step reduction to lower noise, ensure long service life of valve inner parts.

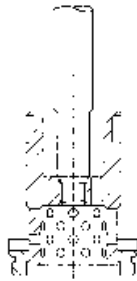

One - step pressure reduction

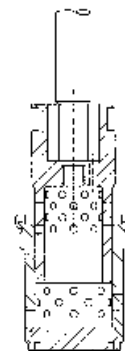

Two - step pressure reduction

### 1.7 Application of orifice plates

In case of above-critical flow, the producer recommends to install one or more orifice plates at the valve outlet to stream-line the process medium flow and to lower the noisiness. The concrete valve execution (No. of orifice plates) is designed according to pressure ratio and it is recommend to consult it with the producer.

### 1.8 Water injection into pipeline outlet

Cooling water injection is carried out by special nozzle with changeable flow. The nozzle is designed to create tiny water drops independently on injected quantity with regard to their most well-proportioned and quickest spraying and vaporescence. The advantage of this design is a possibility of application a low -pressure source, distribution and injection water regulation and separation of the valve trim from their effects. The injection water quantity is controlled by a separate control valve. For proper function the producer recommends to place a filtr into the pipeline in front of the valve.

## 2. DIRECTIONS FOR INSTALLATION AND OPERATING OF VALVE

### 2.1 Preparation before installation

The valves are delivered from the company assembled, adjusted and tested. Before valve's installation into pipeline you must check the data on the name-plate with data mentioned in accompanying documentation. Then check if the valve or the actuator are not damaged and dirty. Pay attention especially to inner spaces and packing surfaces of valve.

The chemicals are applied during the manufacturing, to preserve the valves prior the corrosion. The protecting solution "Konkor" (oil base) is used at inner surface. The grease is applied at flange's faces or welding ends.

In case, the preserving agent should contaminate the medium, it is necessary to rinse/clean the valve with suitable cleaning agent/solution.

The flange's faces and welding ends must be prior the installation always degreased.

## 2.2 Installation of valve into pipeline

The valve must be installed in such direction, that the arrows on the valve body correspond to the process medium flow.

The valves with inlet **DN50–150** can be installed in any position, except the position with actuator under the valve.

For valves with inlet **DN 200-250** and higher, the only possible position is with stem in vertical position and actuator on the top.

Protection of actuator against the radiant heat can be necessary in case of high temperature application. As a basic provision can be made pipeline insulation, actuator turning aside from vertical position, etc.. When the valve is installed into pipeline and actuator is turned aside from vertical position then it is necessary to ensure suitable supporting of actuator.

For proper function of control valve, below-mentioned instructions must be obeyed:

- no excessive forces can be transferred from pipeline to valve.
- the pipeline must be cleaned from dirt before valve installation.
- the valve can not be installed just behind the bend. Pipeline should be straight min. 6x DN in front of the valve. For 702 RV, the length of straight outlet section shall be 20 times the outlet DN, but in all cases a minimum of 4m.
- the inlet valve DN 150 until 250 must be adapted to the space above the valve, so that it was possible to use the lifting device.
- it is recommended to keep clean space around the valve for easy manipulation and service.
- installation itself must be done precisely.

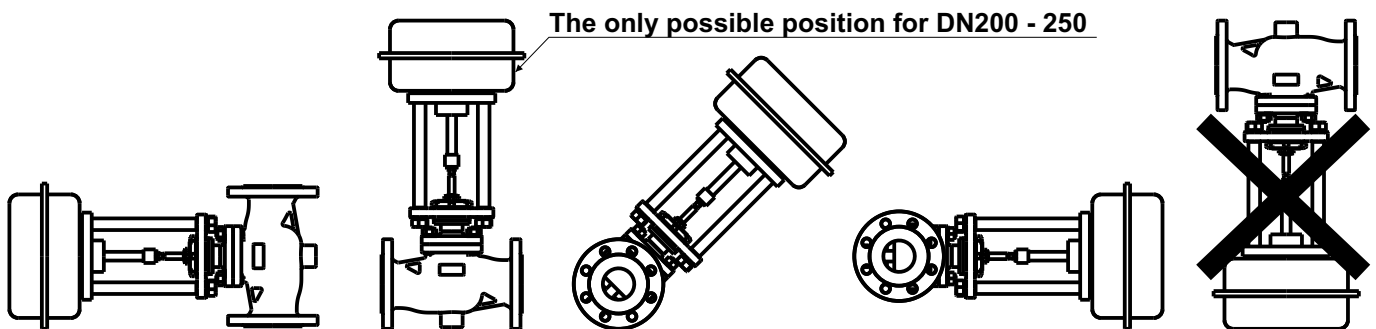

Installation position for valves with electro- or pneumatic actuators

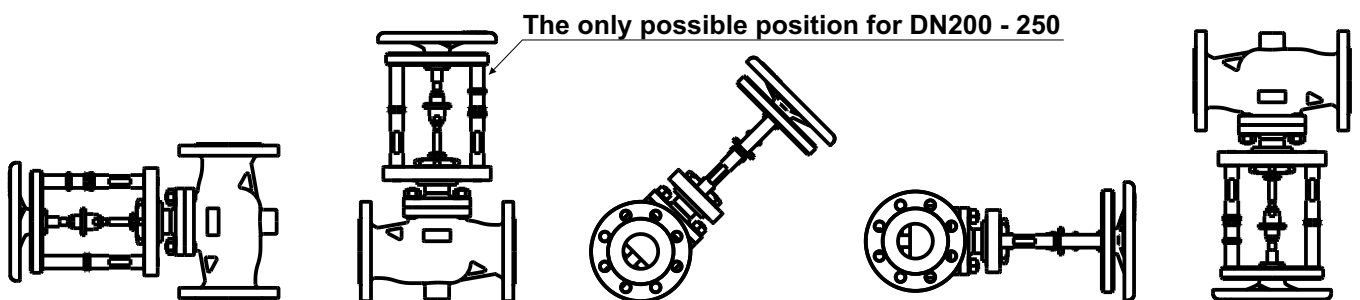

Installation position for valves with hand wheel

## Reduction station RS 702 - weld ends

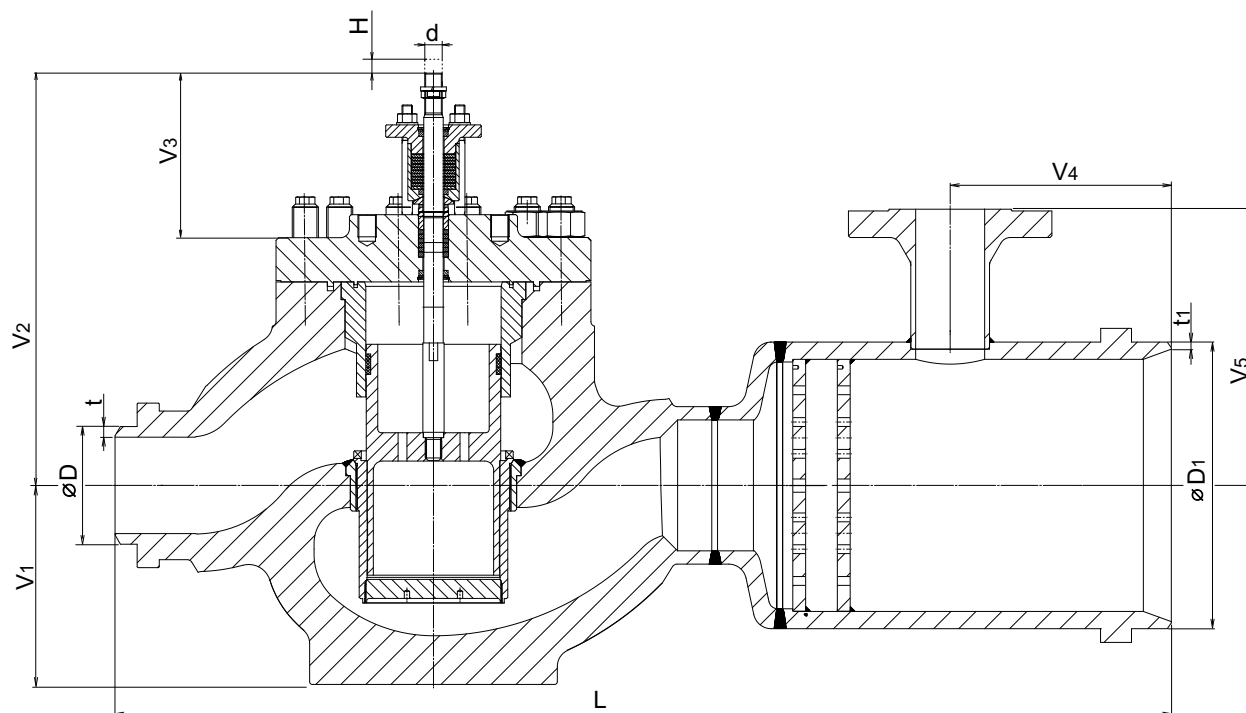

### Dimensions of valves RS 702, weld ends connection \*):

DN	V <sub>1</sub> [mm]	V <sub>2</sub> [mm]	V <sub>3</sub> [mm]	V <sub>4</sub> [mm]	V <sub>5</sub> [mm]	L [mm]	H [mm]	d
50/150	110	320	160	215	262	880	25	M16x1,5
100/200	170	405	160	215	262	1025	40	M20x1,5
125/250	225	466	160	212	314	---	63	
150/200	225	466	160	215	290	1145	63	
150/300	225	466	160	250	343	---	63	
250/500	345	675	210	310	430	1680	100	

\*) There are only recommended combinations of DN for inlet and outlet of the valve.

Note: Missing data will be specified later by the producer.

### Weld ends connection dimensions:

DN	PN							
	16-40	63	100	160	250	320**	400**	16-400
	t	t	t	t	t	t	t	D
	[mm]	[mm]	[mm]	[mm]	[mm]	[mm]	[mm]	[mm]
50	2.9	3.2	4.5	6.3	8	10	14.2	60.3
65	3.2	3.6	5	7	10	13	17.5	76.1
80	3.6	4	5.6	8	12.5	14.2	19	88.9
100	4	5	7	10	14	16	20	114.3
125	4.5	5.6	8	12.5	18	20	23	139.7
150	5	7	10	14	20	23	26	168.3
200	6.3	8	12.5	18	25	28	32	219.1
250	7	10	16	22	32	35	38	273
300	8	12.5	18	25	---	---	---	323.9
350	9	12.5	20	28	---	---	---	355.6
400	11	14	20	32	---	---	---	406.4
500	14	18	25	---	---	---	---	508
600*	18	23	---	---	---	---	---	610
700*	23	---	---	---	---	---	---	721

\* For DN 600 a 700 - dimensions weld ends acc. to LDM.

\*\* For PN 320, 400 - dimensions weld ends acc. to LDM.

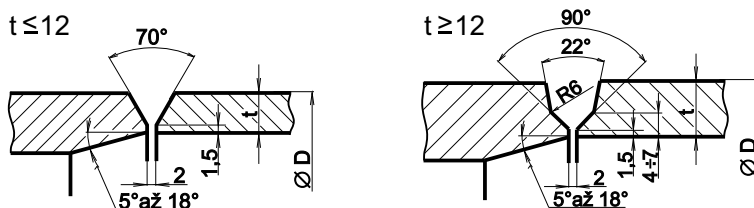

Other shapes of weld ends according to customer requirements.

### 2.2.1 Actuator's connection to electric network

These works can be done only by the experienced workers. It is necessary to keep all safety rules. It is also necessary to follow instructions for installation, operating and service of electric actuator published by producer. Transmitter of position and signalization switches are placed under the cover of actuator, in the case they are as part of the delivery.

In regard of the valve being delivered assembled together with its actuator from the company, basic adjusting and setting of actuator is carried out. The valve is adjusted in closed position by torque switch (so that the valve will be really tight closed) meanwhile the switching off the actuator is adjusted in open position by limit switch. In case the actuator is dismantled from the valve body for any reason such as the valve installation into pipeline etc., it is necessary to check the setting again after the assembly possibly to carry out the complete setting of actuator again. Producer does not take over the guarantee if the damage was caused by improper setting or adjusting of the actuator. In case of need, it is possible to ask for such service from service organization of the producer.

The length of the cables to actuator should be selected so that the actuator could be disassembled from the valve without any need for the cables unplugging from the actuator's terminal board.

**WARNING:** It's necessary to observe the mechanical stroke indicator placed at actuator's yoke or directly at the electromotor, if the valve is operated (opened or closed) by hand wheel. The extra care must be taken near to OPEN and CLOSE position. Neither position nor torque switches are in function in such case and there is a danger of valve or actuator serious damage. It's strongly prohibited to use any mechanical tools (force boosters) for hand wheel operation.

### 2.2.2 Pneumatic actuator connection

These work may be carried out by trained personnel only. It is necessary to follow instructions for installation, operation and maintenance of pneumatic actuators issued by the producer of the actuator.

Connection of pneumatic actuator to air supply is done by plastic, copper or stainless-steel tubes, recommended dimension is 8x1 mm. The 12x1 mm tubes are recommended for the actuators with membrane area larger than 600 cm<sup>2</sup> or in case the length of air pipeline is more than 10m.

Before valve commissioning, the data, given in the actuator and positioner ID plate (especially air supply maximum pressure), should be checked/compared with given specification. If the pressure of air supply is higher, the pressure reduction valve must be used.

As the valve is supplied with actuator as a complet, the basic setting is also carried out. In case the actuator was removed from the valve, it is necessary to check this setting or set the actuator once again. The producer does not take over the damage caused by wrong setting of the actuator. In case of need, the assistance of our subsidiary LDM Service can be required.

In case of pressure air regulator (air supply to pneumatic actuator) fixed directly on the valve/actuator yoke, the regulator must be placed in vertical position (draincock/draincup down), see picture. If the valve mounting position is known during the valve-actuator assembly, the right position is set on the production line/during final test.

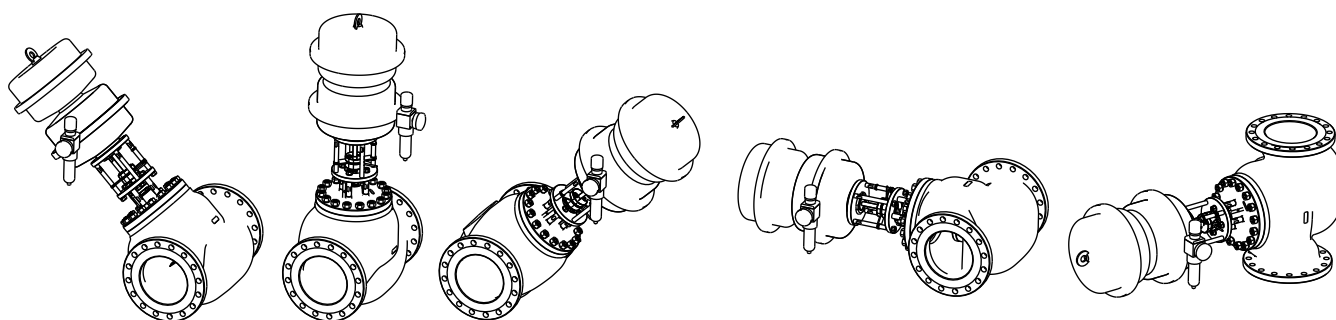

Examples of filter/regulator position

### 2.2.3 Checking after installation

Piping system should be pressured after valve installation and then checked if there is no leak. Check the packing set tightness as well. Then check the proper function of actuator by doing a few strokes.

## 2.3 Operating and Service

The valves are equipped with graphite packing rings. The packing set is loaded with system of disc springs "LIVE LOADING". During the operation, it is **necessary** to maintain the gap between the flange and packing bushing in the range **0,5 - 1,5mm** (pic. No.1). From the factory, the value of 0,5 mm is set. The tightening is carried out by four nuts M12. The producer recommends to check this value more often (about twice a month) after starting new packing set. Later, once a half of year is enough.

Picture No.1

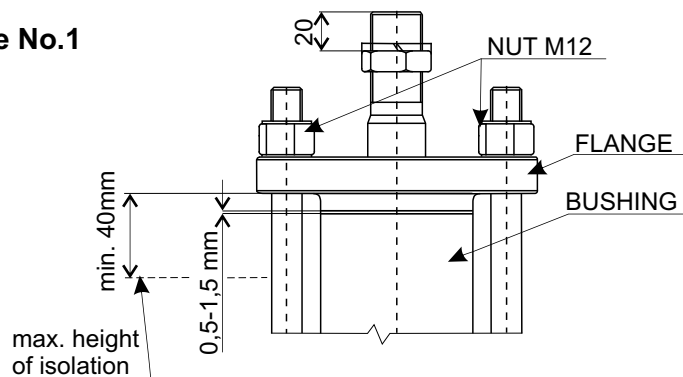

### 2.3.1 Exchange of packing set

If there is a need to exchange the packing because of worse tightness, it's recommended to ask LDM service company for technical instructions for dismantling and assembly of the "LIVE LOADING" packing or to ask them for a exchange of it.

### 2.3.2 Elektrické pohony

Elektrické pohony nevyžadují speciální údržbu a obsluhu. Je však zapotřebí dodržovat pokyny uvedené v montážním návodu vydaném výrobcem pohonů. Při výskytu poruchy postupovat dle montážního návodu nebo objednat odborný servis.

### 2.3.3 Warming-through and putting fittings out of operation

Warming-through fittings:

Fittings have to be filled and warmed-through by regulating the steam supply and drainage so that the trend of the temperature increase is observed, i.e. so that the increase in the temperature of fittings does not exceed the given temperature jump per minute (see the table). After the required temperature is reached, the operation of the steam piping is regulated depending on the need of the given appliance.

Valve	Carbon material of body	Alloy material of body
DN 15-150, PN 16-160 DN 15-65, PN 160-400	6°C/min	4°C/min
DN 80-250, PN 160-400	5°C/min	3°C/min

If the required temperature of the fitting needs to be reached faster, it is necessary to secure permanent warming-through, e.g. by means of a by-pass.

Putting fittings out of operation:

If possible, the decline of the temperature of alloy steel fittings that are cooling down is to be as slow as the temperature increase in warming-through. If a faster temperature decline is detected, the decline has to be slowed down until the temperature drops to 300 °C; then the piping is let cool down without any intervention. The cooling rate does not have to be monitored in fittings made of carbon steels.

### 2.3.4 Thermal and acoustic insulation

The type and dimensions of the insulation are as stated in the design. Only the insulation above the cover of the fitting has to have its height adjusted to provide a free access for monitoring the compression of the packing or for tightening (see point 2.3, pic. 1).

## 2.4 Elimination of defects and malfunctions

If a defect is detected on the valve (leakage, leakage of packing or bonnet sealing, etc.), it is necessary to ensure its repair immediately otherwise a permanent damage may occur to sealing surfaces and other parts exposed to effects of leaking medium.

**Prior to any repair work on the valve, make sure that piping system is free of pressure!**

## Elimination of defects and malfunctions

Defect	Possible cause	Elimination of defect
Valve leakage	- insufficient linear force of the actuator	- check the function and setting of the actuator possibly positioner
	- seizure of impurity in seat area	- open and close the valve fully
	- damaged sealing surfaces of the plug and seat	- it is necessary to lap plug and seat or replace damaged parts - requires trained personnel
Packing leakage	- sealing force of graphite packing is too low	- tighten the graphite packing or add another sealing ring (see 2.3)
	- packing is worn or damaged	- change the whole packing set (see 2.3.1) - requires trained personnel
	- damaged stem	- replace packing and stem - requires trained personnel
Leakage of bonnet	- low adherence pressure to gasket - damaged gasket	- tighten screws - to change bonnet gasket - requires trained personnel
Leakage of body	- damage caused by aggressiveness, abrasion, or erosion of media	- it is need to change of body - trained personnel required
Increased noise	- exceeding of operating parameters - presence of undesirable particle in throttling system	- must be consulted with the producer - it is necessary to disassemble valve, clean the throttling system, eventually change the damaged parts - requires trained personnel
Stem won't move	- no supply to actuator (electric or pneumatic)	- electric actuators: check supply and feeding voltage - pneumatic actuators: check supply and feeding pressure
	- actuator control signal failure	- measure the value of input control signal
	- the defect of actuator or its accessories	- follow the instructions for actuator or require trained personnel
	- graphite packing tightened too much	- loosen the packing and retighten it just to ensure tightness
	- seizure inside the valve due to impurities	- it is necessary to dismantle the valve and replace damaged parts - trained personnel required
Stem jerky movement	- insufficient actuator force	- compare parameters of the product with the real parameters - if OK, ensure responsible service personnel
	- damaged positioner	- follow the instructions issued by its producer, possibly ensure trained service personnel
Valve won't move in full range of its stroke	- wrong setting of end position switches	- check the setting of the switches
	- pneumatic and electrohydraulic actuators: hand wheel got stuck in wrong position	- adjust the hand wheel into its basic position
	- pneumatic actuators: feeding pressure is too low	- ensure the required pressure of supply air
	- pneumatic actuators wrongly adjusted or defected positioner	- readjust the positioner acc. to instructions issued by its producer
	- impurities inside the valve	- close and open the valve fully, possibly ensure trained service personnel
Wrong (too high or too low) temperature of steam after desuperheating	- failure of cooling water control valve	- check the function and seat leakage of cooling water control valve
	- failure of injection head/nozzle	- remove the nozzle and check it's function/opening by pressurized water (pressure 0.2 or 0.4 MPa)

If the valve is in guarantee period, it is necessary to ensure authorised service for all service except tightening of graphite packing!

## 2.5 Spare parts

Spare parts are not part of valve delivery. They must be ordered separately. For the spare parts order, following data must be written: type of a valve, nominal diameter DN, Serial valve´s number, name of a spare part.

Recommend spare parts for 3 and 5 years of operation:

Parts for 3 years of operation	Additional parts for 5 years of operation *)
<ul style="list-style-type: none"> <li>- packing set (stuffing box complete)</li> <li>- bonnet gasket</li> <li>- bonnet gasket-inner</li> <li>- plug's sealing rings (only for balanced plug with graphite rings sealing)</li> <li>- plug's wiping rings</li> </ul>	<p><u>balanced plug's sealing – graphite rings</u></p> <ul style="list-style-type: none"> <li>- plug with stem (welded assembly)</li> <li>- seat (seat cage)</li> <li>- plug's guide</li> </ul> <p><u>balanced plug's sealing – metal U-ring seal</u></p> <ul style="list-style-type: none"> <li>- plug with stem (welded assembly)</li> <li>- seat (seat cage)</li> <li>- insert</li> <li>- metal U-ring seal</li> </ul>

\*) It's recommended for 5-years spare parts ordering to order 2 sets for 3-years operation and 1 set of additional parts for 5-years operation.

## 2.6 Guarantee conditions

The producer does not guarantee the operation and safety of the product under conditions different from data given in the catalogue data sheet. Any using of the valve under different conditions shall be consulted with the producer. Defects of the valve caused by impurities in process medium shall be considered as out of guarantee terms. The producer does not take over the guarantee if any change was made by the user without prior written consent from the producer (except the packing tightening).

## 2.7 Transportation and storage

During transport and storage, the valve must not be exposed to water or placed in environment with relative humidity exceeding 90 %.

With respect to used actuators, the temperature during transport and storage shall be within the range of -20 to 55°C. Weld ends must be protected with blinds (these are part of delivery).

Suitable tools/devices should be used for valve lifting during the transport and installation (e.g. lifting harness entwined around weld ends, actuator yoke etc.).

**Never lift the valve by the lifting device fixed on the actuator only!**

Example of lifting device usage.

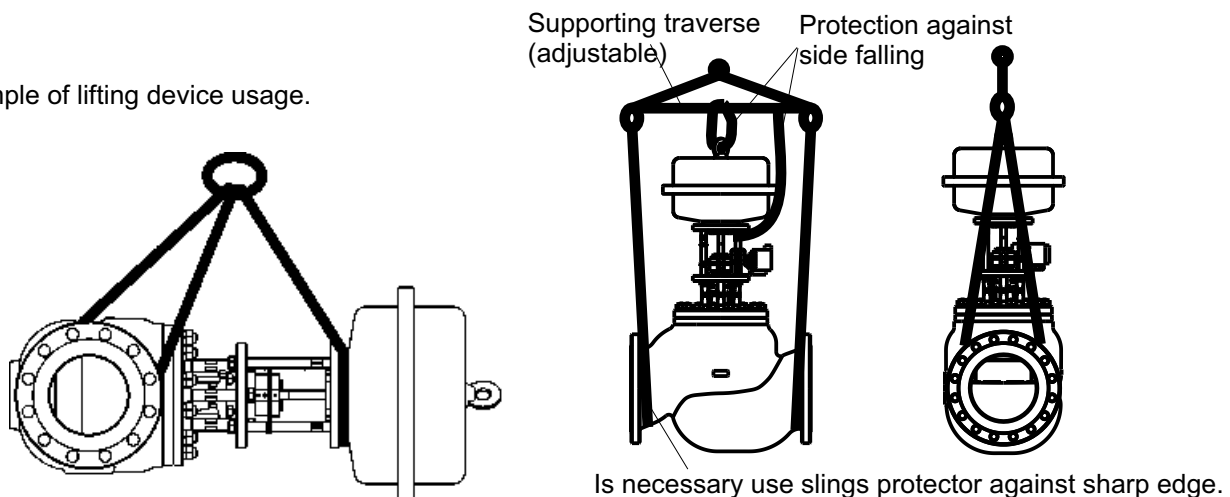

It is necessary to make sure the valve can not be damaged during transport. **Special attention shall be paid to the valve stem, stroke indicator and outside accessories fixed to the actuator.** If the valves are stored for more than 3 years, the producer recommends to carry out professional inspection of the valves.

## 2.8 Waste disposal

Packaging and the valves (after their scrapping) shall be disposed off in the common way, e.g. by handing over to a specialized company for a disposal (body and metal parts - metal scrap, packaging + other non-metallic parts - communal waste).



## Valve complete specification No. for ordering RV 70x

		XX	X X X	X X X	X X X X	XX	XX	/XXX-	XXX
1.Valve	Steam conditioning station	RS							
2.Type of valve	Control valves, straight-through,with extended outlet and with injection of water into outlet pipeline		702						
3.Actuator <sup>1)</sup> Pneu. actuator only to DN 150	Electric actuator			E					
	Electric actuator			P					
	Electric actuator Modact MTR <sup>1)</sup>			EPD					
	Electric actuator Modact MTN Control <sup>1)</sup>			EYA					
	Electric actuator Modact MTP Control <sup>1)</sup>			EYA					
	Electric actuator AUMA SA 07.6			EAE					
	Electric actuator AUMA SA Ex 07.6			EAF					
	Electric actuator AUMA SAR 07.6			EAG					
	Electric actuator AUMA SAR Ex 07.6			EAH					
	Electric actuator AUMA SAR 10.2			EAI					
	Electric actuator AUMA SAR Ex 10.2			EAL					
	Electric actuator Schiebel rAB5			EZG					
	Electric actuator Schiebel exrAB5			EZH					
	Electric actuator Flowserve PO 700			PFC					
Electric actuator Flowserve PO 1502			PFD						
4.Connection	weld ends				4				
5.Body material	Cast steel 1.0619 (-20 to 400°C)				1				
	Stainless steel 1.4931 (-20 to 600°C)				5				
	Alloy steel 1.7379 (-20 to 550°C)				6				
	Alloy steel 1.7357 (-20 to 550°C)				7				
	Other material				9				
6.Packing set	Grafit - LIVE LOADING				5				
7.Multi-step reduction	Jednostupňová				1				
	Dvoustupňová				2				
8.Flow characteristic	Linear - leakage class III.					L			
	Equal percentage - leakage class III.					R			
	Linear - leakage class V.					D			
	Equal percentage - leakage class V.					Q			
9.No.of orifice plates	Max. 3						X		
10.Nominal pressure	PN inlet / outlet							xx/xx	
11.Operating tem.°C	According to sort of medium							XXX	
12.Nominal diameter	DN - on request								xx/xx

**Ordering example:** Steam conditioning station DN 50/100, PN 160/100, with electric actuator AUMA SAR 7.5, body material cast steel 1.0619, connection - weld ends, packing set - graphite, two - step reduction, one plate in outlet, characteristic linear, leakage class III., is marked as:  
**RS 702 EAG 4152 L1 (160/100)/400-(50/100)**

## Maximum permissible working pressure according to EN 12516-1[MPa]

Material	PN	Temperature [ °C ]											
		100	150	200	250	300	350	400	450	500	550	575	600
Cast steel 1.0619	160	14.98	14.21	13.45	12.29	11.14	10.37	9.60	5.89	---	---	---	---
	250	23.41	22.21	21.01	19.21	17.41	16.20	15.00	9.20	---	---	---	---
	320	29.97	28.43	26.89	24.59	22.28	20.75	19.21	11.78	---	---	---	---
	400	37.45	32.53	33.61	30.73	27.85	25.93	24.01	14.73	---	---	---	---
Alloy steel 1.7357	160	16.00	16.00	16.00	16.00	16.00	14.91	13.66	12.62	9.99	4.70	---	---
	250	25.00	25.00	25.00	25.00	25.00	23.29	21.34	19.72	15.60	7.34	---	---
	320	32.00	32.00	32.00	32.00	32.00	29.81	27.32	25.25	19.98	9.39	---	---
	400	40.00	40.00	40.00	40.00	40.00	37.26	34.14	31.56	24.97	11.74	---	---
Alloy steel 1.7379	160	16.00	16.00	16.00	16.00	16.00	15.02	13.66	12.62	10.53	5.63	5.51	2.39
	250	25.00	25.00	25.00	25.00	25.00	23.47	21.34	19.72	16.45	8.80	8.60	3.73
	320	32.00	32.00	32.00	32.00	32.00	30.04	27.32	25.25	21.07	11.27	11.01	4.78
	400	40.00	40.00	40.00	40.00	40.00	37.55	34.14	31.56	26.33	14.09	13.76	5.98
Alloy steel 1.7380	160	16.00	16.00	16.00	16.00	16.00	15.02	13.66	12.62	10.53	5.63	5.51	2.39
	250	25.00	25.00	25.00	25.00	25.00	23.47	21.34	19.72	16.45	8.80	8.60	3.73
	320	32.00	32.00	32.00	32.00	32.00	30.04	27.32	25.25	21.07	11.27	11.01	4.78
	400	40.00	40.00	40.00	40.00	40.00	37.55	34.14	31.56	26.33	14.09	13.76	5.98
Alloy steel 1.7383	160	16.00	16.00	16.00	16.00	16.00	15.02	13.66	12.62	10.53	5.63	5.51	2.39
	250	25.00	25.00	25.00	25.00	25.00	23.47	21.34	19.72	16.45	8.80	8.60	3.73
	320	32.00	32.00	32.00	32.00	32.00	30.04	27.32	25.25	21.07	11.27	11.01	4.78
	400	40.00	40.00	40.00	40.00	40.00	37.55	34.14	31.56	26.33	14.09	13.76	5.98
Stainless steel 1.4931	160	16.00	16.00	16.00	16.00	16.00	15.02	13.66	12.62	10.53	9.32	7.13	4.18
	250	25.00	25.00	25.00	25.00	25.00	23.47	21.34	19.72	16.45	14.56	11.14	6.54
	320	32.00	32.00	32.00	32.00	32.00	30.04	27.32	25.25	21.07	18.64	14.26	8.37
	400	40.00	40.00	40.00	40.00	40.00	37.55	34.14	31.56	26.33	23.29	17.82	10.46

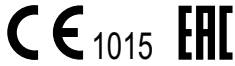

## ADDRESS OF FACTORY

LDM, spol. s r.o.  
Litomyšlská 1378  
560 02 Česká Třebová  
Czech Republic

tel.: +420 465 502 511  
fax: +420 465 533 101  
E-mail: sale@ldm.cz  
<http://www.ldmvalves.com>

## REGIONAL OFFICES

LDM, spol. s r.o.  
Office in Prague  
Podolská 50  
147 01 Praha 4  
Czech Republic

tel.: +420 241087360  
fax: +420 241087192  
E-mail: tomas.suchanek@ldm.cz

LDM, spol. s r.o.  
Office in Ústí nad Labem  
Ladova 2548/38  
400 11 Ústí nad Labem - Severní Terasa  
Czech Republic

tel.: +420 602708257  
E-mail: tomas.kriz@ldm.cz

## SERVICE ORGANIZATION

LDM servis, spol. s r.o.  
Litomyšlská 1378  
560 02 Česká Třebová  
Czech Republic

tel: +420 465502411-13  
fax: +420 465531010  
E-mail: servis@ldm.cz

## LDM SUBSIDIARIES ABROAD

OOO "LDM Promarmatura"  
Jubilejnyi prospekt, dom.6a, of. 601  
141407 Khimki  
Moscow Region  
Russia

tel.: +7 495 7772238  
fax: +7 495 7772238  
mobile: +7 9032254333  
e-mail: inforus@ldmvalves.com

TOO "LDM"  
Shakirova 33/1, kab. 103  
100012 Karaganda  
Kazachstan

tel.: +7 7212566936  
fax: +7 7212566936  
mobile: +7 7017383679  
e-mail: sale@ldm.kz

LDM, Bratislava s.r.o.  
Mierová 151  
821 05 Bratislava  
Slovakia

tel: +421 243415027-8  
fax: +421 243415029  
E-mail: ldm@ldm.sk  
<http://www.ldm.sk>

LDM Armaturen GmbH  
Wupperweg 21  
D-51789 Lindlar  
Deutschland

tel: +49 2266 440333  
fax: +49 2266 440372  
mobile: +49 1772960469  
E-mail: ldmarmaturen@ldmvalves.com

LDM, Polska Sp. z o.o.  
ul. Bednorza 1  
40-384 Katowice  
Polska

tel: +48 327305633  
fax: +48 327305233  
mobile: +48 601354999  
E-mail: ldmpolska@ldm.cz

LDM Bulgaria Ltd.  
z.k.Mladost 1  
bl.42, floor 12, app.57  
1784 Sofia  
Bulgaria

tel: +359 2 9746311  
fax: +359 2 8771344  
mobile: +359 888925766  
E-mail: ldm.bg@ldmvalves.com

[www.ldmvalves.com](http://www.ldmvalves.com)

LDM, spol. s r.o. reserves the right to modify or improve the designs or specifications of such products at any time without notice  
Guarantee and after guarantee service provided.