

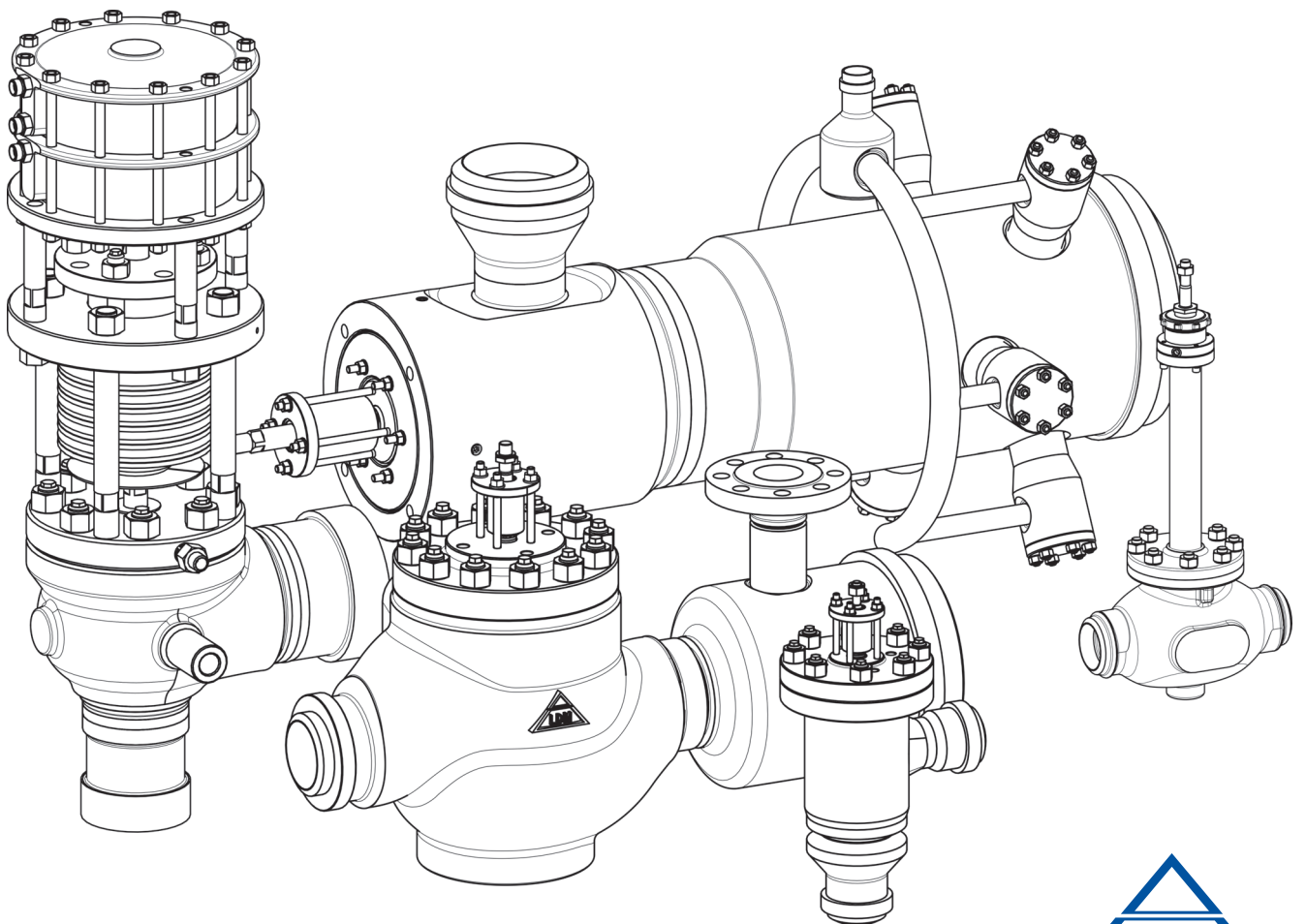

OVERVIEW OF PRODUCTION RANGE

Product segment 01 up to PN 630

Power generation



01.25.GB

Series		300 line				500 line	700 line		
Marking of type		RV 3x0 UV 3x0	RV 3x2	CV 3x0 SV 3x0	CV 3x2	UV 526	RV 701	RV 702	RS 702
Type of valve	Control valve	●	●	●	●		●	●	
	Steam-conditioning station								●
	Safety valve								
	Shut-off valve	●		●		●			
	Check valve								
	Special valve								
Application	For liquids	●	●	●	●	●	●		
	For gases, steam	●	●	●	●	●		●	●
Execution	Straight-through	●	●	●	●	●	●	●	●
	Angle								
	"Z"								
	Three-way								
Connection	Flanged	●	●	●	●	●	●	●	●
	Weld ends	●	●	●	●	●	●	●	●
Diameter Nominal DN	(inlet)	15 - 400	25 - 400			10 - 65	25 - 250	25 - 250	25 - 250
	(outlet)							25 - 1000	150 - 1000
Pressure Nominal PN	(inlet)	16 - 63	16 - 63			63 - 250	16 - 400	16 - 400	16 - 400
	(outlet)							16 - 400	16 - 400
Range of Kvs	[m ³ /h]	0,01 - 1600	1,6 - 1600			1,53 - 29,4	0,1 - 630	0,25 - 630	1,25 - 630
Diameter Nominal NPS ⁶⁾	(inlet)			1/2" - 16"	1" - 16"				
	(outlet)								
Pressure Nominal Class ⁶⁾				150 ⁴⁾ - 600	150 ⁴⁾ - 600				
Range of Cv ⁶⁾	[US Galon/min]			0,012-1850	1,85-1850				
Number of orifice plate		1	1	1	1	1	1 - 4 ¹⁾	1 - 4 ¹⁾	1 - 4 ¹⁾
Body material	Grey cast iron								
	Spheroidal cast iron								
	Cast steel	●	●	●	●	●	●	●	●
	Alloy steel	●	●	●	●	●	●	●	●
	Stainless steel	●	●	●	●	●	●	●	●
Flow characteristic	Linear	●	●	●	●		●	●	●
	Equal-percentage	●	●	●	●		●	●	●
	LDMspline®	●	●	●	●				
	Parabolic	●	●	●	●				
	On-off	●		●		●			
Actuating	Hand wheel	●	●	●	●	●	●	●	
	Electromechanic actuator	●	●	●	●	●	●	●	●
	Pneumatic actuator	●	●	●	●		●	●	●

1) Labyrinth

2) Further reduction: max. 1 fixed orifice plate

3) Material of weld ends only. The body made of 1.4922 (stainless steel X20 CrMoV 11-1) as standard

4) CLASS 150 weld ends only

5) Angle and angle with two inlets

6) Execution of valves according to ASME

7) For DN 20 - 100, PN 63 input insert only

700 line			800 line		900 line			
CV 701	CV 702	CS 702	RV 805	RV 806	RV 902	RS 902	UV 926	ZV 926
●	●		●	●	●			
		●				●		
							●	
								●
●			●	●			●	●
	●	●			●	●	●	●
●	●	●					●	●
			●		●	●		
				●				
●	●	●					●	●
●	●	●	●	●	●	●	●	●
			25 - 100	25 - 100	50 - 250 80 - 700	50 - 250 80 - 700	10 - 65	10 - 65
			160 - 400	160 - 400	100 - 630 16 - 400	100 - 630 16 - 400	63 - 630	63 - 630
			0,63 - 50	0,63 - 50	8 - 500	8 - 500	1,5 - 30	1,5 - 30
1" - 10"	1" - 10" 1" - 40"	1" - 10" 6" - 40"						
150 - 2500	150 - 2500	150 - 2500						
0,11 - 728	0,29 - 728	1,45 - 728						
1 - 4 ¹⁾	1 - 4 ¹⁾	1 - 4 ¹⁾	1 - 4	1 - 4	1 - 2 ¹⁾	1 - 2 ¹⁾	1	1
●	●	●	● ³⁾	● ³⁾	●	●	●	●
●	●	●	● ³⁾	● ³⁾	●	●	●	●
●	●	●			●	●	●	●
●	●	●	●	●	●	●		
●	●	●	●	●	●	●		
							●	●
●	●						●	
●	●	●	●	●	●	●	●	
●	●	●	●	●	●	●	●	

Series		Řada G					Control cock	Safety valves	
Marking of type		G 45	G 46	G 47	G 92	G 93	RK 601	SiZ 1508	PV 1509
Type of valve	Control valve	●	●	●	●	●			
	Steam-conditioning station								
	Safety valve							●	●
	Shut-off valve								
	Check valve								
	Special valve						●		
Application	For liquids	●		●	●	●	●		
	For gases, steam		●			●	●	●	●
Execution	Straight-through	●	●	●					
	Angle				●	● ⁵⁾		●	●
	“Z”								
	Three-way						●		
Connection	Flanged	●	●	●				●	●
	Weld ends	●	●	●	●	●	●	●	●
Diameter Nominal DN	(inlet)	150 - 400	65 - 300	125 - 300	150	150	200 - 600	25 - 350	65 - 350
	(outlet)		125 - 600				200 - 600	40 - 600	100 - 600
Pressure Nominal PN	(inlet)	16 - 100	16 - 250	125 - 500	400	400	40 - 100	16 - 400	---
	(outlet)		10 - 160					10 - 160	
Range of Kvs	[m ³ /h]	45 - 1100	16 - 1125	10 - 435	191	60 - 250	to 25 000		
Diameter Nominal NPS ⁶⁾	(inlet)								
	(outlet)								
Pressure Nominal Class ⁶⁾									
Range of Cv ⁶⁾	[US Galon/min]								
Number of orifice plate		1	1 ²⁾	1	4	5			
Body material	Grey cast iron								
	Spheroidal cast iron								
	Cast steel	●	●	●			●	●	●
	Alloy steel	●	●	●	●	●	●	●	●
	Stainless steel						●	●	●
Flow characteristic	Linear	●	●	●		●			
	Equal-percentage	●	●	●	●	●			
	LDMspline®								
	Parabolic								
	On-off								
Actuating	Hand wheel								
	Electromechanic actuator	●	●	●	●	●	●		
	Pneumatic actuator								

1) Labyrinth

2) Further reduction: max. 1 fixed orifice plate

3) Material of weld ends only. The body made of 1.4922 (stainless steel X20 CrMoV 11-1) as standard

4) CLASS 150 weld ends only

5) Angle and angle with two inlets

6) Execution of valves according to ASME

7) For DN 20 - 100, PN 63 input insert only

Safety valves			Steam desuperheating						
PV 61	PV 63	PV 25	VH	VHP	VHF	CHP	CHPE	CHPF	CHPR
●	●	●							
			●	●	●	●	●	●	●
●	●	●	●	●	●	●	●	●	●
						●	●	●	●
●	●	●							
●	●	●	●	●	●	●	●	●	●
						●	●		●
20 - 400 32 - 500	20 - 400 32 - 500	15 - 200	25, 40, 50	20 and 25	15, 20, 25	100 - 600	40 - 200	50 - 200	200 - 600
16 - 100	16 - 100	16 and 40	16 - 250	16 - 250	16 - 400	16 - 400	16 - 320	16 - 400	16 - 400
			2,4 - 7,2	1,44	0,003 - 0,9				
●	●	●							
●	●								
●	●	●	●	●	●	●	●	●	●
● ⁷⁾	● ⁷⁾		●	●	●	●	●	●	●
	●	●	●	●	●	●	●	●	●

HISTORY AND PRESENT TIME OF LDM

LDM spol, s r. o. was established by three partners in the mid of 1991. From the very beginning it has always been and also for the future will be focused on production of industrial valves. The history of production of industrial valves in Česká Třebová is dated since 1909 when Mr. Josef Jindra founded a company with the homonymic firm name.

In 1919 he amalgamated with Mr. Václav Šrefl and established the company Šrefl and Jindra, later registered as Jindra and Šrefl. Then production programme included wide variety valves from small brass water valves over gas valves up to steam valves made of cast steel, including steam safety valves. At the end of 1929 both partners were separating and both founded own factory in Česká Třebová for manufacturing of industrial valves. Nowadays the former Šrefl's factory is the part of production facilities of LDM.

After nationalization in 1948 both companies changed their names several times till 1975 when became a part of worldwide known Czechoslovak concern Sigma Lutín. After so-called velvet revolution is the Sigma concern separated to different companies which were privatized or restored. Also the Sigma Česká Třebová was privatized and became an joint-stock company, nevertheless the company became bankrupt in 1995. LDM bought it and became the continuator of more than 100-years of valves manufacturing tradition in Česká Třebová. Currently LDM is strongly export-oriented company with more than 220 employees and LDM industrial valves can be found worldwide particularly in power generation, industrial processes, heating, ventilation, air conditioning, gas industry and other applications. LDM product range includes control valves, shut-off valves and safety valves in pressure ranges from PN 6 to PN 400 and dimensions from DN 10 to DN 600. The wide product portfolio is a reason why LDM valves can be found in almost all fields of human activities where it is necessary to control a flow, pressure or temperature.

Čís. 355. VYSOKOTLAKÉ UZAVÍRACÍ VENTILY.
Provozní tlak 25 př. 50 atm.

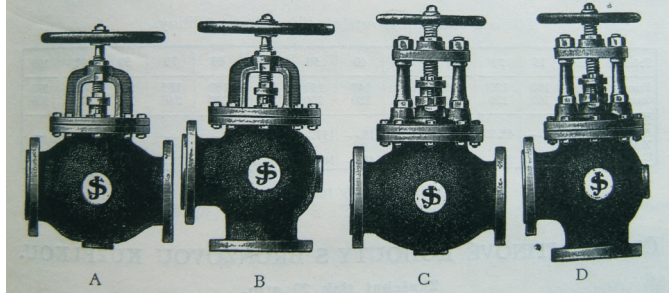

Period catalogue of Jindra and Šrefl company in 20's



LDM facility today

LDM has its own subsidiary in Slovakia, Poland, Bulgaria, Russia and Kazakhstan and many authorized partners in other countries.

LDM has also well-established and certified integrated quality management system according to standards ISO 9001, ISO 14001 and OHSAS 18001 which it is ensuring permanent quality and a high level of all company processes.

As follows from above mentioned, LDM company dignity continues the long-time tradition of industrial valves manufacturing in Česká Třebová to which proudly claims as its successor. The company's future consist in fulfilment

of the vision that was already defined in 1995:

- World-famous, leading and trend-making company in the development, production, sale and service of industrial valves
- Dynamic company allowing to all their employees achievement of high level of self-fulfillment and social prestige
- Reputable company whose name stands for high utility value, quality and reliability

Successful fulfillment of the vision results from the conviction, that three main pillars on which the company stands are strong. The first pillar are our customers and their needs whose satisfaction is directed effort of the whole company to. The second pillar are our products. LDM is company which firmly stands on its own development, so the cycle of a development, design, manufacturing, sale and service is closed. The third and no less important pillar are own employees who are able to respond flexibly to constantly changing market requirements and who are able to actively and jointly form the company future.

Ultimately, not only many awards from international exhibitions from past, but also many OEM products, whose LDM manufacture and delivers to many other producers under their own brand, recognize the high quality of LDM production and confirm the right way, which LDM took in 1991.



A sample of manufacturing portfolio of LDM nowadays

300 line

Control and shut-off valve RV/UV 3x0 and CV/SV 3x0

Description

The valves of the series RV/UV 3x0 and CV/SV 3x0 are single-seated control and shut-off valves of a unit construction design to control or closing a flow and a pressure of liquids, vapours and gases without mechanical impurities. The valves are designed for applications in heating, ventilation, power generation and chemical processing industries.

The valves can be actuated with hand wheel or with electric or pneumatic actuators of the following producers: ZPA Nová Paka (for RV/UV 3x0), ZPA Pečky (for CV/SV 3x0), Regada, Auma, Schiebel, A.Hock, Flowserve or others.

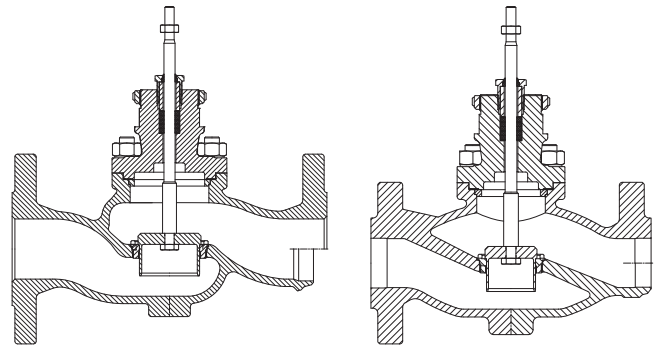

RV/UV 3x0

CV/SV 3x0

Technical data	RV/UV 3x0	CV/SV 3x0
Execution	Control valve, single-seated, straight-through, flanged or with weld ends	
Diameter nominal range	DN 15 to 400	NPS 1/2" to 16"
Nominal pressure	PN 16 to 63	Class 150, 300, 600
Operating temper. range	-10 to 550°C	-10 to 550°C (14 to 1020°F)

Control valve RV 3x2 and CV 3x2

Description

The valves of the series RV 3x2 and CV 3x2 are single-seated pressure balanced control valves of a unit construction design to control a flow and a pressure of liquids, vapours and gases without mechanical impurities. The valves are designed for applications in heating, ventilation, power generation and chemical processing industries.

The valves can be actuated with hand wheel or with electric or pneumatic actuators of the following producers: ZPA Nová Paka (for RV 3x2), ZPA Pečky (for CV 3x2), Regada, Auma, Schiebel, A.Hock, Flowserve or others.

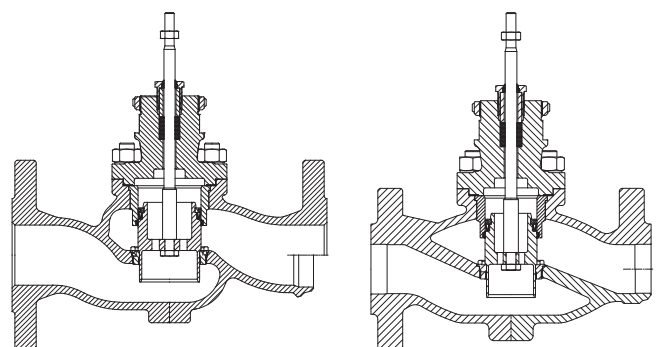

RV 3x2

CV 3x2

Technical data	RV 3x2	CV 3x2
Execution	Control valve, single-seated, straight-through with pressure-balanced plug, flanged or with weld ends	
Diameter nominal range	DN 25 to 400	NPS 1" to 16"
Nominal pressure	PN 16 to 63	Class 150, 300, 600
Operating temper. range	-10 to 550°C	-10 to 550°C (14 to 1020°F)

500 line

Shut-off valve UV 526

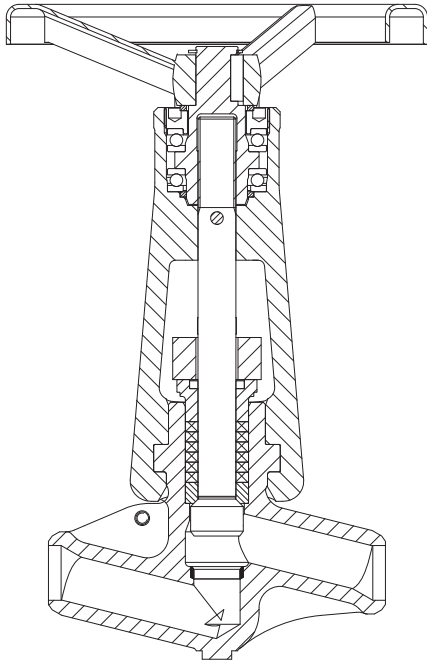

Description

Shut-off valves UV 526 are single-seated globe valves designed for shutting off flow of a media. The valves could be optionally equipped with shaped plug for rough control in case of demand.

The valves are designed for applications in power generation and chemical processing industries. They are suitable for shutting off water, steam and other liquids and gases which are compatible with used materials of the valve body and internal materials.

Shut-off valves UV 526 are designed to be actuated with hand wheel or with multi-turn electric actuators.

Technical data	UV 526
Execution	Shut-off valve, single-seated, straight-through, two-way, flanged or with weld ends
Diameter nominal range	DN 10 to 65
Nominal pressure	PN 63 to 250
Operating temper. range	-10 to 600°C

700 line

Control valve RV 701 and CV 701

Description

The valves of the series RV 701 and CV 701 are single-seated control valves of a unit construction designed to control a flow and a pressure of liquids without mechanical impurities. The pressure-balanced, multi-step throttling trim is always designed with regard to the resistance to creation and effects of cavitation and noisiness. The valves are equipped with "Live Loading" packing. The common process medium is water or other media compatible with a valve body material carbon steel, alloy steel or stainless steel and its inner parts.

The valves can be actuated with electric or pneumatic actuators of the following producers: Regada, ZPA Pečky, Auma, Schiebel, Flowserve, A.Hock or others.

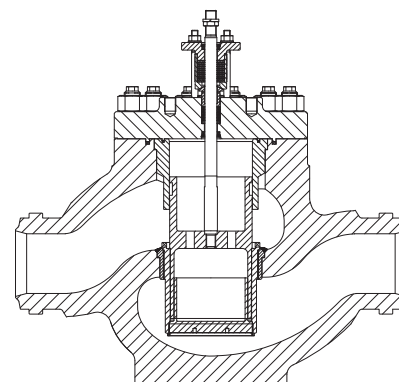

Technical data	RV 701	CV 701
Execution	Control valve, single-seated, straight-through, pressure-balanced plug, flanged or with weld ends	
Diameter nominal range	DN 25 to 250	NPS 1" to 10"
Nominal pressure	PN 16 to 400	Class 150 to 2500
Operating temper. range	-10 to 600°C	-10 to 600°C (14 to 1112°F)

Control valve with extended outlet and orifice plate RV 702 and CV 702

Description

The valves with extended outlet of the series RV 702 and CV 702 are single-seated control valves of a unit construction designed to control a flow and a pressure of vapours and gases without mechanical impurities. The pressure-balanced, multi-step throttling trim is always designed to eliminate the valve's high differential pressures with a high resistance to wearing caused by flow and effects of expanding steam. It also ensures a low noisiness level. The valves are equipped with "Live Loading" packing.

The common process media is saturated or superheated steam and other media compatible with a valve body material carbon steel, alloy steel or stainless steel and its inner parts.

The valves can be actuated with electric or pneumatic actuators of the following producers: Regada, ZPA Pečky, Auma, Schiebel, Flowserve, A.Hock or others.

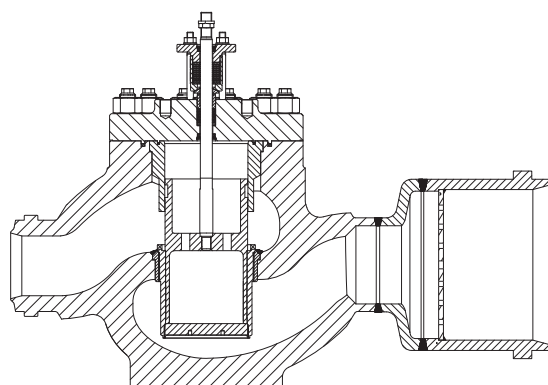

Technical data	RV 702	CV 702
Execution	Control valve, single-seated, straight-through, pressure-balanced plug, orifice plate in extended outlet, flanged or with weld ends	
Diameter nominal range	inlet DN 25 to 250, outlet DN 25 to 1000	inlet NPS 1" to 10", outlet NPS 1" to 40"
Nominal pressure	inlet PN 16 to 400, outlet PN 16 to 400	inlet Class 150 to 2500, outlet Class 150 to 2500
Operating temper. range	-10 to 600°C	-10 to 600°C (14 to 1112°F)

Steam-conditioning station RS 702 and CS 702

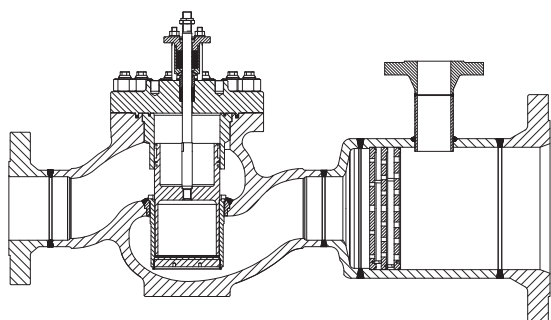

Description

Steam conditioning station RS 702 and CS 702 is single-seated control valve of a unit construction designed for water injection into the extended outlet. The pressure-balanced, multi-step throttling trim is designed to eliminate high differential pressures within the valve and ensure the low noisiness. It ensures a high resistance to wearing caused by medium flow and to effects of the expanding steam. Cooling water is injected into the extended outlet with a specially designed nozzle (VH, VHF or VHP) with changeable flow. The valve is equipped with "Live Loading" packing.

The valves are designed to regulate the pressure and temperature of steam without mechanical impurities.

The connection is designed for both domestic and foreign actuators of the following producers: Regada, ZPA Pečky, Auma, Schiebel, Flowserve, A.Hock or others.

Technical data	RS 702	CS 702
Execution	Control valve, single-seated, straight-through, with pressure-balanced plug, with orifice plate and injection head at extended outlet, flanged or with weld ends	
Diameter nominal range	inlet DN 25 to 250, outlet DN 150 to 1000	inlet NPS 1" to 10", outlet NPS 6" to 40"
Nominal pressure	inlet PN 16 to 400, outlet PN 16 to 400	inlet Class 150 to 2500, outlet Class 150 to 2500
Operating temper. range	-10 to 600°C	-10 to 600°C (14 to 1112°F)

Control valve RV 805

Description

The valves of the series RV 805 are single-seated angle control valves of a unit construction that provides a great variety of control elements. Thanks to such a combination, it is possible to satisfy the customers' requirements and demands. The valve is equipped with "Live Loading" packing.

The valves series RV 805 are especially designed as control elements for control of injection water supply into steam pipeline. Thanks to their high nominal working pressure (PN 400) and ability to manage high differential pressures (ordinarily 15 MPa, max. 20 MPa), owing to a multi-step pressure reduction, the valves can be used in every application to which any other common valve cannot resist due to its low service life.

The valves can be actuated with electric or pneumatic actuators of the following producers: Regada, ZPA Pečky, Auma, Schiebel, Flowserve or others.

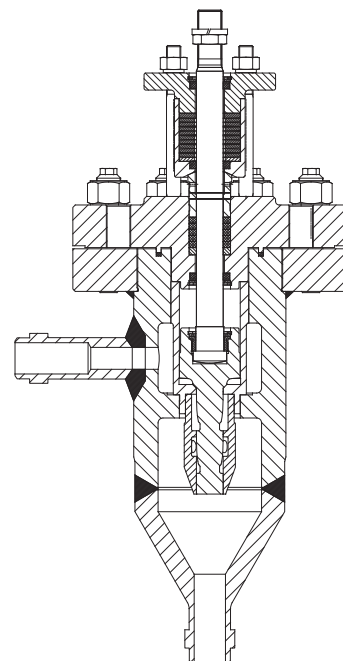

Technical data	RV 805
Execution	Control valves, single-seated, angle, with weld ends
Diameter nominal range	DN 25, 40, 50, 65, 80, 100
Nominal pressure	PN 160 to 400
Operating temper. range	-10 to 550°C

Control valve RV 806

Description

The valves of the series RV 806 are single-seated valves of a unit construction that provides a great variety of control elements. Thanks to such a combination, it is possible to satisfy the customers' requirements and demands. The valve is equipped with "Live Loading" packing.

The valves series RV 806 are especially designed as control elements for control of injection water supply into steam pipeline. Thanks to their high nominal working pressure (PN 400) and ability to manage high differential pressures (ordinarily 15 MPa, max. 20 MPa), owing to a multi-step pressure reduction, the valves can be used in every application to which any other common valve cannot resist due to its low service life.

The valves can be actuated with electric or pneumatic actuators of the following producers: Regada, ZPA Pečky, Auma, Schiebel, Flowserve or others.

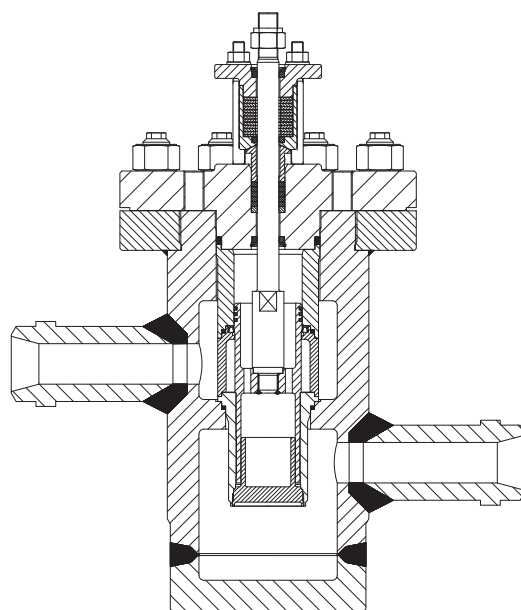

Technical data	RV 806
Execution	Control valve, single-seated "Z-shaped", with weld ends
Diameter nominal range	DN 25, 40, 50, 65, 80, 100
Nominal pressure	PN 160 to 400
Operating temper. range	-10 to 550°C

900 line

Control valve RV 902 with extended outlet and orifice plate

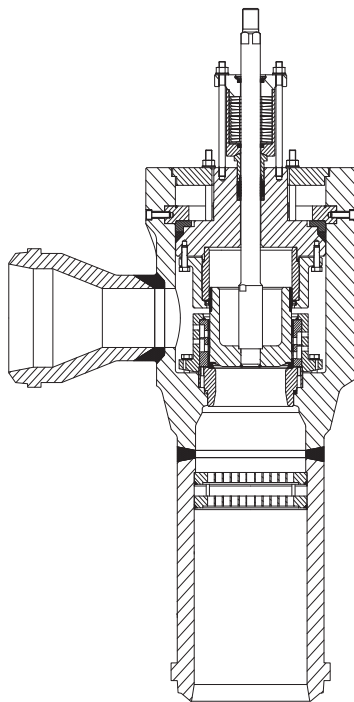

Description

The valves with extended outlet of the series RV 902 are single-seated angle control valves of a unit construction designed to control a flow and a pressure of vapours and gases without mechanical impurities. The pressure-balanced, multi-step throttling trim is always designed to eliminate the valve's high differential pressures with a high resistance to wearing caused by flow and effects of expanding steam. It also ensures a low noisiness level. The valves are equipped with "Live Loading" packing.

The common process media is saturated or superheated steam and other media compatible with a valve body material carbon steel, alloy steel or stainless steel and its inner parts.

The valves can be actuated with electric or pneumatic actuators of the following producers: Regada, ZPA Pečky, Auma, Schiebel, Flowserve or others. It is also possible to use fast acting electrohydraulic actuators for quick closing or opening.

Technical data	RV 902
Execution	Angle control valve, single-seated, pressure-balanced plug, orifice plate in extended outlet, with weld ends
Diameter nominal range	inlet DN 50 to 250, outlet DN 80 to 700
Nominal pressure	inlet PN 100 to 630, outlet PN 16 to 400
Operating temper. range	20 to 600°C

Steam-conditioning station RS 902

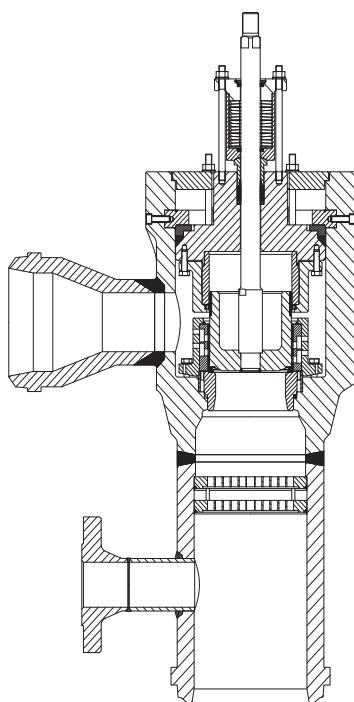

Description

Steam conditioning stations of the series RS 902 are single-seated angle control valves of a unit construction designed to control a flow and a pressure of steam and simultaneous cooling water injection into the extended outlet. The pressure-balanced, multi-step throttling trim is always designed to eliminate high differential pressures within the valve and ensure the low noisiness. It ensures a high resistance to wearing caused by medium flow and to effects of the expanding steam. Cooling water is injected into the extended outlet with a specially designed injection head (VH, VHF and VHP). The valves are equipped with "Live Loading" packing.

The valves can be actuated with electric or pneumatic actuators of the following producers: Regada, ZPA Pečky, Auma, Schiebel, Flowserve or others. It is also possible to use fast acting electrohydraulic actuators for quick closing or opening.

Technical data	RS 902
Execution	Angle control valve, single-seated, pressure-balanced plug, orifice plate and injection head in extended outlet, with weld ends
Diameter nominal range	inlet DN 50 to 250, outlet DN 80 to 700
Nominal pressure	inlet PN 100 to 630, outlet PN 16 to 400
Operating temper. range	20 to 600°C

Shut-off valve UV 926

Description

Shut-off valves UV 926 are single-seated globe valves designed for shutting off flow of a media. The valves could be optionally equipped with shaped plug for rough control in case of demand.

The valves are designed for applications in power generation and chemical processing industries. They are suitable for shutting off water, steam and other liquids and gases which are compatible with used materials of the valve body and internal materials.

Shut-off valves are designed to be actuated with hand wheel or with multi-turn electric actuators of the following producers: ZPA Pečky, Regada, Auma, Schiebel and Sipos, or pneumatic actuators A.Hock.

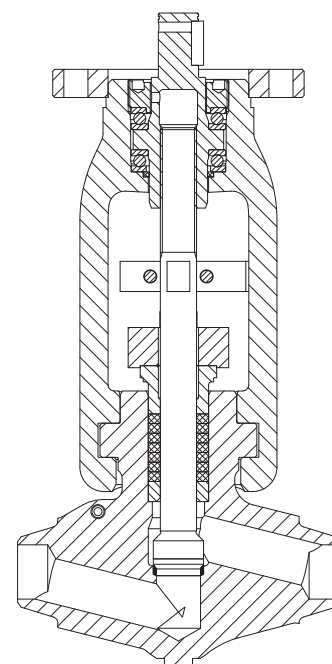

Technical data	UV 926
Execution	Shut-off valve, single-seated, straight-through, two-way, flanged or with weld ends
Diameter nominal range	DN 10 to 65
Nominal pressure	PN 63 to 630
Operating temper. range	-10 to 650°C

Check valve ZV 926

Description

The valves ZV 926 is single-seat check valve and they are intended for back flow prevention of a medium.

The valves are designed for applications in power generation and chemical processing industries. They are suitable for shutting off water, steam and other liquids and gases which are compatible with used materials of the valve body and internal materials.

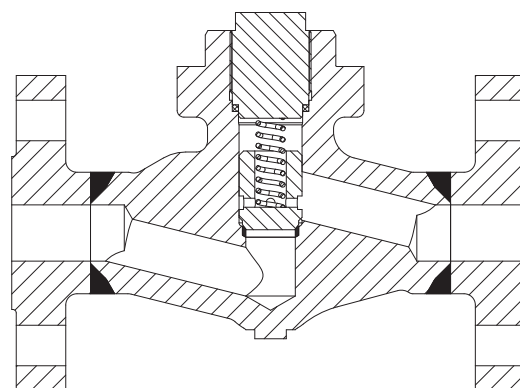

Technical data	ZV 926
Execution	Check valve, single-seated, straight-through, two-way, flanged or with weld ends
Diameter nominal range	DN 10 to 65
Nominal pressure	PN 63 to 630
Operating temper. range	-10 to 650°C

Series G

Control valve G 45

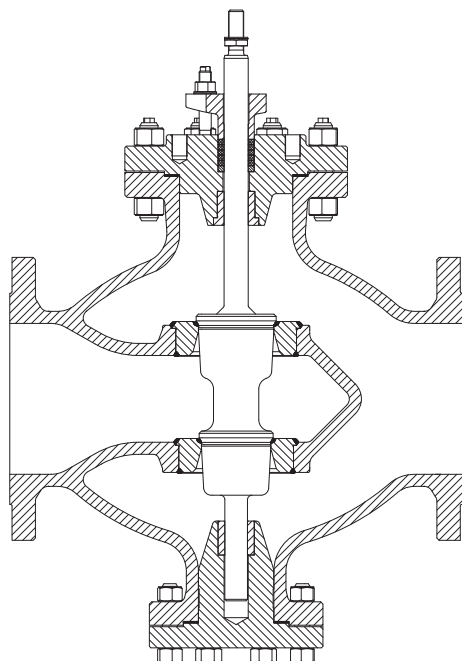

Description

The valve is double-seated, lever-actuated designed to be actuated with an electric or a pneumatic actuator possibly with an electric or a hydraulic cylinder. It is also possible to use linear or rotative actuator. Its control plug is always designed according to the parameters specified in the order and according to the required type of flow characteristic.

The valves are used as control and reduction element in industrial applications - power plants, heating plants, technological processes, especially for control and reduction of water.

The valve can be delivered with lever actuators of the following producer: ZPA Pečky, possibly with linear actuators ZPA Pečky, Regada Prešov or rotative actuators Auma or Schiebel.

Technical data	G 45
Execution	Control valves, double-seated, straight-through, flanged or with weld ends
Diameter nominal range	DN 150 to 400
Nominal pressure	PN 16 to 100
Operating temper. range	-10 to 550°C

Control valve G 46

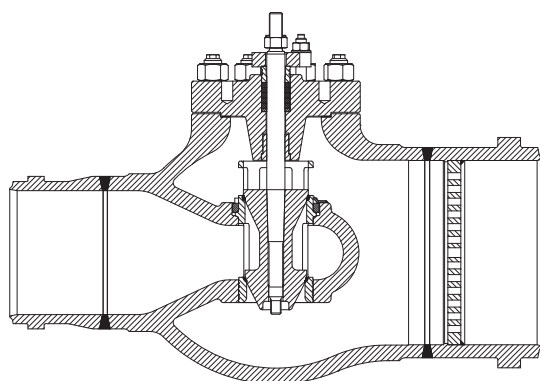

Description

The valve is double-seated, lever-actuated, designed to be actuated with an electric actuator or a hydraulic or pneumatic cylinder. The control valve plug is always designed according to the parameters specified in the order and according to the requested type of flow characteristic.

The valves are used as control and reduction element in industrial applications - power plants, heating plants, technological processes, especially for control and reduction of water.

The valve can be actuated with lever actuators ZPA Pečky.

Technical data	G 46
Execution	Control valves, double-seated, straight-through, with extended outlet, flanged or with weld ends
Diameter nominal range	inlet DN 65 to 300, outlet DN 125 to 500
Nominal pressure	inlet PN 16 to 250, outlet PN 10 to 160
Operating temper. range	-10 to 575°C

Control valve G 47

Description

The valve is piston type equipped with control cage, lever-actuated designed to be actuated with an electric actuator. It is also possible to use linear or rotative actuators. Its control cage is always designed according to the parameters specified in the order and according to the requested type of flow characteristic.

The valves are used as control and reduction elements for industrial applications for power plants and heating plants especially for regulation of feeding water flow and pressure into steam boilers.

The valve can be actuated with lever actuators ZPA Pečky.

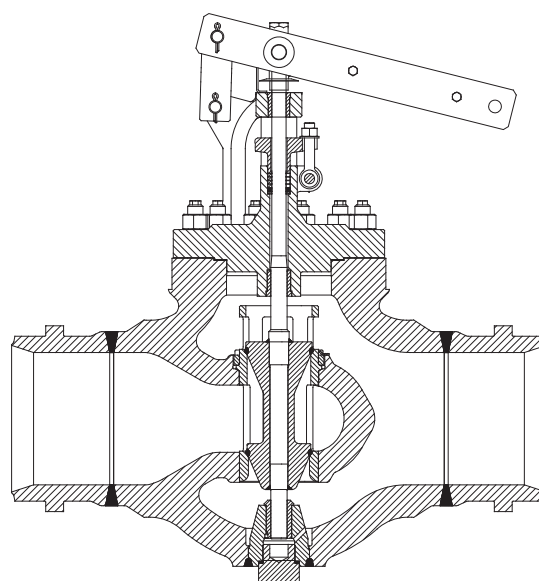

Technical data	G 47
Execution	Control valve (feeding), straight-through, flanged or with weld ends
Diameter nominal range	DN 125 to 300
Nominal pressure	PN 125 to 500
Operating temper. range	-10 to 400°C

Control valve G 92

Description

The valve is single-seated, designed to be actuated with an electric rotating actuator. The piston type plug moves in a special control cage with holes and cross section grooves that, when the valve opens, gradually enlarge which provides a smooth regulation.

The valves serves as a control valve applicable to where it is necessary to change the flow water pressure from its maximum value to minimum or vice versa.

The valves are supplied with the actuators of the following producers: ZPA Pečky or possibly with AUMA or Schiebel.

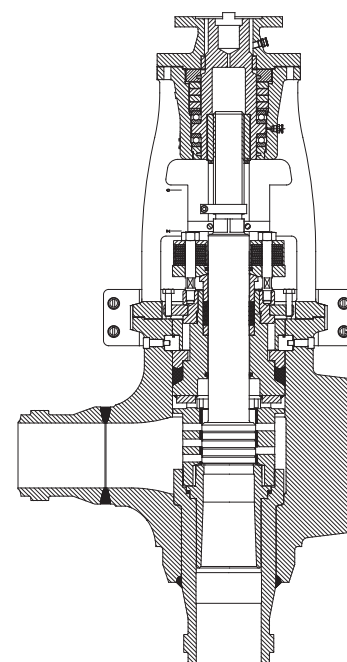

Technical data	G 92
Execution	Control valves (starting), angle, with weld ends
Diameter nominal range	DN 150
Nominal pressure	PN 400
Operating temper. range	-10 to 550°C

Control valve G 93

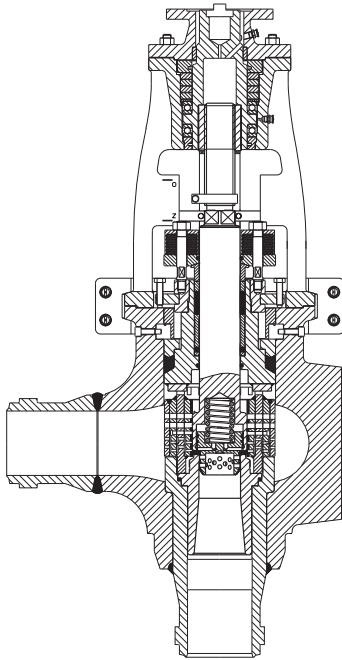

Description

The valve is single-seated, angle (angle with two inlets), welding ends. Control mechanism with a multi-stage pressure reduction is made by special control cage with holes and cross section grooves and two plugs. Main piston plug, which is a part of the valve stem, provides media flow control and ensures also a tightness when the valve is closed. Internal perforated plug reduces the pressure drop at stroke begins to prevent wear of sealing surfaces. Valve is equipped by a Chesterton stuffing box, type "Live Loading". Valve is designed to be actuated with an electric rotating actuator ZPA Pečky, Auma or Schiebel.

Technical data	G 93
Execution	Control valves (starting), angle, with weld ends
Diameter nominal range	DN 150
Nominal pressure	PN 400
Operating temper. range	-10 to 550°C

Control cock

Three-way control cock RK 601

Description

Control cock RK 601 is a three way valve with turn throttling organ (segment) for diverting or mixing of the medium flow. Construction of the cock doesn't allow to close the medium.

Optimized shape of the channels by CFD achieves high values of flow rate as well as by low pressure drop.

Cock is designed for connection with electromechanical actuators of various producers acc. to customer requirement. Flange F14 connection.

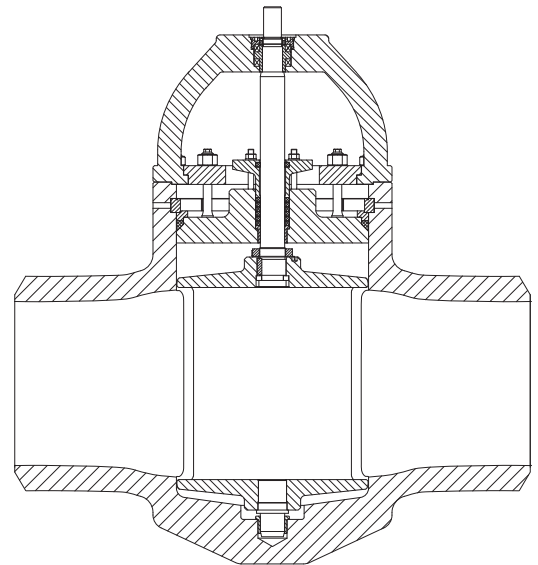

Technical data	RK 601
Execution	Control cock, three-way, diverting function, with weld ends
Diameter nominal range	DN 200 to 600
Nominal pressure	PN 40 to 100
Operating temper. range	-10 to 600°C

Safety valves

Full-lift safety valve with additional loading type SiZ 1508

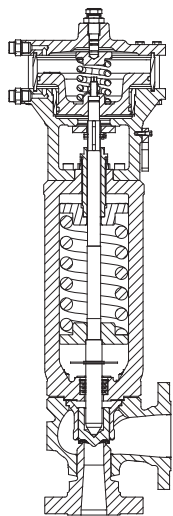

Description

The full-lift safety valve with additional loading is a valve designed for automatic protection of a pressure equipment (steam boilers, pressure pipelines, steam-conditioning stations, pressure vessels, turbine extraction etc.) against unpermitted pressure increase over allowable limit.

The safety valves SiZ 1508 are designed for steam, air, and non-aggressive gases and vapours.

Technical data	SiZ 1508
Execution	Full-lift safety valve with additional loading, flanged or with weld ends
Diameter nominal range	inlet DN 25 to 350, outlet DN 40 to 600
Nominal pressure	inlet PN 16 to 400, outlet PN 10 to 160
Opening pressure	max 400 barg
Operating temper. range	max 620°C

Full-lift safety valve with additional loading type PV 1509

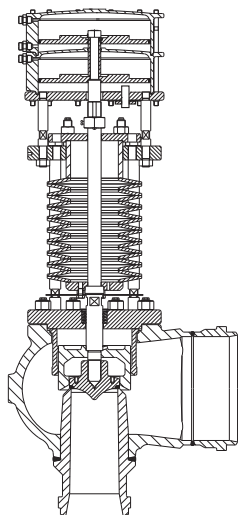

Description

The full-lift safety valve with additional loading is a valve designed for automatic protection of a pressure equipment (steam boilers, pressure pipelines, steam-conditioning stations, pressure vessels, turbine extraction etc.) against unpermitted pressure increase over allowable limit.

The safety valves PV 1509 are designed for steam, air, and non-aggressive gases and vapours.

Technical data	PV 1509
Execution	Full-lift safety valve with additional loading, flanged or with weld ends
Diameter nominal range	inlet DN 65 to 350, outlet DN 100 to 600
Opening pressure	max 250 barg
Operating temper. range	max 620°C

Control unit RP 5330

Description

Pneumatic control unit RP 5330 is designed for control of spring loaded safety valves with additional pneumatic loading (pneumatic actuator), type SiZ 1508 and PV 1509, manufactured by LDM Co. Ltd., Česká Třebová, respective for control of other types of safety valves operated by pneumatic cylinder. Control unit can be supplied in version for normal ambient temperature or in version for low ambient temperature down to -60°C. This low temperature design is furnished with outer insulation and inner heating system.

Spring loaded full lift safety valves PV 61 and PV 63

Description

Spring loaded full lift safety valves Series PV 61 and PV 63 are designed and certified as a safety device for automatic protection of pressure equipment (as a boiler, a pressure vessel, a pressure reduction station, pipeline, etc.) against excessive pressure. The spring, which causes the closing/sealing force, is designed for specific range of set pressures, the fine setting is made through adjusting screw. The valve is equipped with lever, which serves for manual valve opening or functional test under the normal operating conditions of protected pressure equipment.

Because the valves PV 63 are with closed bonnet they can be delivered both in normal (standard) or gas-tight execution. The valves are determined for liquids (PV 63 only), steam, air and other gases which are compatible with used materials of the valve body and internal parts.

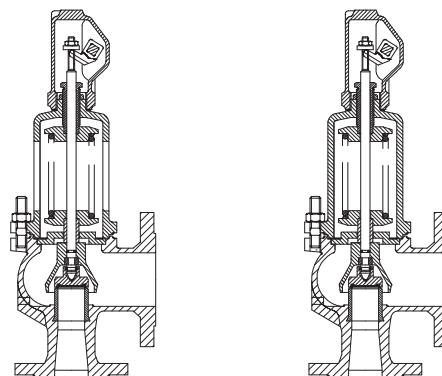

PV 61

PV 63

Technical data	PV 61	PV 63
Execution	Spring loaded full lift safety valve, angle, flanged, with open bonnet	Spring loaded full lift safety valve, angle, flanged, with closed bonnet
Diameter nominal range	inlet DN 20 to 400, outlet DN 32 to 500	
Nominal pressure	PN 16 to 100	
Opening pressure	0,25 to 95 barg	
Operating temper. range	5 to 450°C	

Spring loaded proportional safety valves PV 25

Description

Spring loaded proportional safety valves Series PV 25 are designed and certified as a safety device for automatic protection of pressure equipment (as a boiler, a pressure vessel, a pressure reduction station, pipeline, etc.) against excessive pressure. The spring, which causes the closing/sealing force, is designed for specific range of set pressures, the fine setting is made through adjusting screw. The valve is equipped with lever, which serves for manual valve opening or functional test under the normal operating conditions of protected pressure equipment.

Because the valves PV 25 are with closed bonnet they can be delivered both in normal (standard) or gas-tight execution. The valves are designed to use for liquids, steam, air and other gases which are compatible with used materials of the valve body and internal parts.

Technical data	PV 25
Execution	Spring loaded proportional safety valve, angle, flanged, with closed bonnet
Diameter nominal range	DN 15 to 200
Nominal pressure	PN 16 and 40
Opening pressure	0,2 to 40 barg
Operating temper. range	5 to 400°C

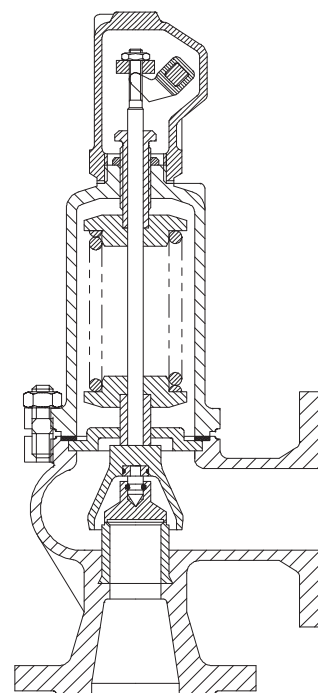

Steam desuperheating

Mechanical injection head VH

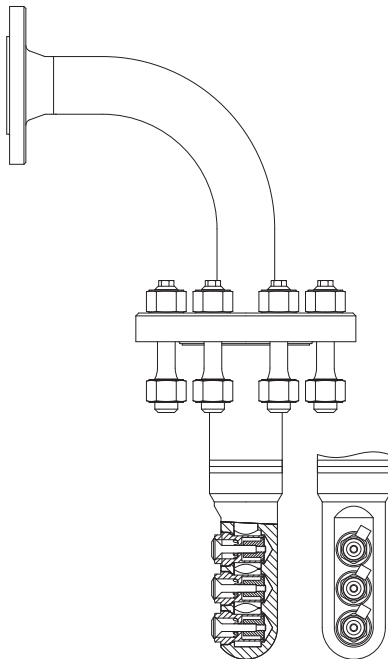

Description

The injection head (further in text only VH) is a device designed to control the temperature of steam. VH is equipped with a mechanical spraying nozzle with changable flow.

VH is designed especially for industrial applications such as low-pressure steam production in heating, steam circuits in power plants or technological processes.

Technical data	VH
Execution	Injection head with 1, 2 or 3 nozzles
Diameter nominal range	Steam pipeline connection ... DN 80 Cooling water connection ... DN 25, 40, 50
Nominal pressure	PN 16 to 250
Operating temper. range	20 to 600°C

Drive-steam injection head VHP

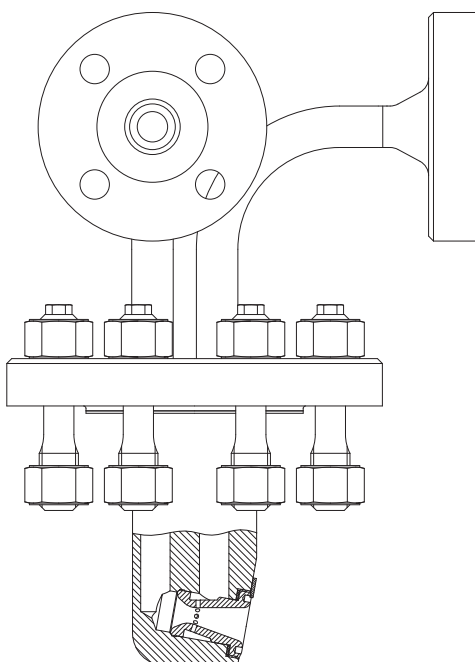

Description

Drive-steam injection head (further in text only VHP) is a device designed to regulate the temperature of the steam. VHP is equipped with Laval nozzle which sprays the injection water with the aid of kinetic energy of drive steam expanding in the nozzle.

VHP is designed for precise and economic injection of cooling water into steam. VHP is especially designed for industrial applications such as production of low-pressure steam or stem production in technology.

Technical data	VHP
Execution	Drive-steam injection head with Laval nozzle
Diameter nominal range	Steam pipeline connection ... DN 80 Cooling water connection ... DN 20 and 25
Nominal pressure	PN 16 to 250
Operating temper. range	20 to 600°C

Mechanical injection head VHF

Description

The injection head with a nozzle with fixed flow (further in text only VHF) is a device designed to control the temperature of steam. VHF could be equipped with one to three mechanical spraying nozzles with fixed flow. VHF is designed especially for industrial applications such as low-pressure steam production in heating, steam circuits in power plants or technological processes.

Technical data	VHF
Execution	Injection head with 1, 2 or 3 nozzles
Diameter nominal range	Steam pipeline connection ... DN 50 and 65 Cooling water connection ... DN 15 to 25
Nominal pressure	PN 16 to 400
Operating temper. range	20 to 600°C

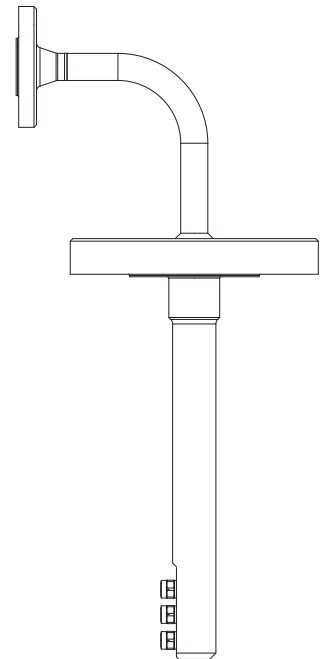

Desuperheater CHP

Description

Desuperheater (further in text only CHP) is a body that is put directly into the steam pipeline and subsequently serves for connection with either mechanical injection head VH, VHF or drive-steam injection head VHP. According to dimensions of the pipeline and necessary intensity of cooling, the body can be equipped with more inlets for connection of VH, VHF or VHP. It is designed especially for industrial applications such as low-pressure steam production in heating or the steam production for technological processes.

Technical data	CHP
Execution	Desuperheater, flanged or with weld ends
Diameter nominal range	Steam pipeline connection ... DN 100 to 600 Injection head connection ... DN 50 to 80
Nominal pressure	PN 16 to 400
Operating temper. range	20 to 600°C

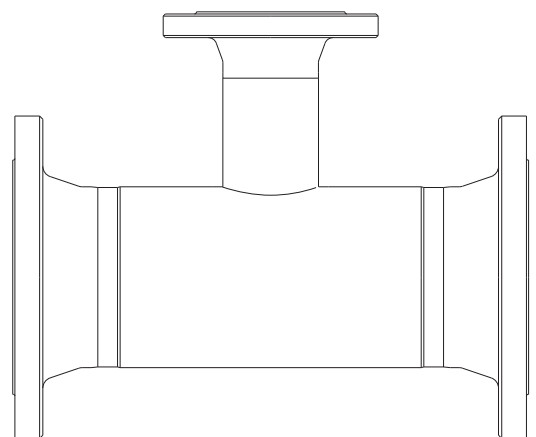

Desuperheater CHPE

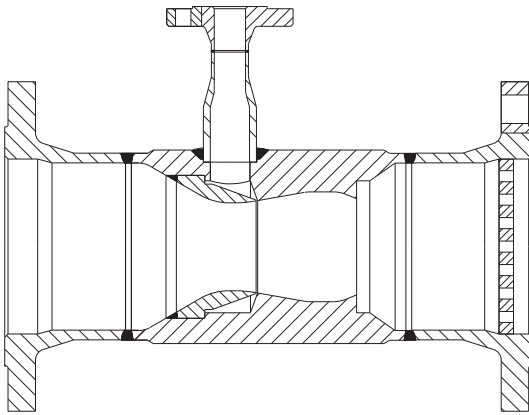

Description

Desuperheater (further the CHPE only) is a device designed to control the temperature of steam. Internal shape is formed by Venturi tube where there is a significant increase of speed. This increased speed positively influences the quality of water atomization as well as evaporation velocity of injection water. The orifice plate is included in the output port of CHPE to increase the cooling effect. Due to construction of CHPE it is capable of injecting water from zero values.

CHPE is especially designed for industrial applications such as low-pressure steam production in heating, steam circuits in power plants or technological processes.

Technical data	CHPE
Execution	Desuperheater, flanged or with weld ends
Diameter nominal range	Steam pipeline connection ... DN 40 to 200 Cooling water connection ... DN 15 to 50
Nominal pressure	PN 16 to 320
Operating temper. range	20 to 600°C

Desuperheater CHPF

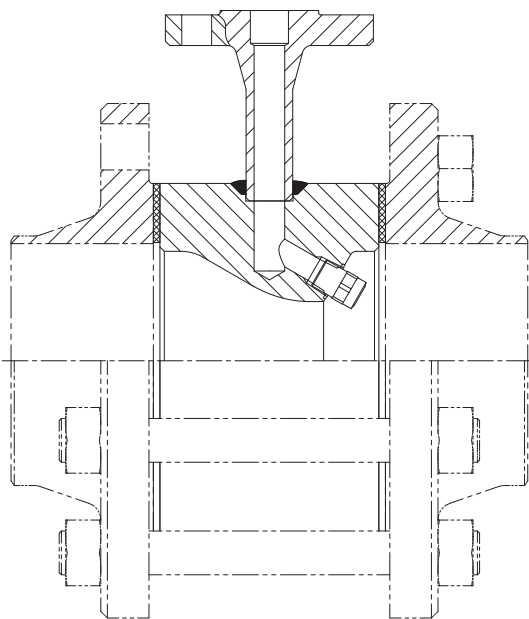

Description

Desuperheater with a nozzle with fixed geometry (further the CHPF only) is a device designed to control the temperature of steam. CHPF could be equipped with one or more mechanical nozzles with fixed flow and to be installed between flanges using long bolts.

CHPF is especially designed for industrial applications such as low-pressure steam production in heating, steam circuits in power plants or technological processes.

Technical data	CHPF
Execution	Desuperheater with a nozzle with fixed geometry, flanged
Diameter nominal range	Steam pipeline connection ... DN 50 to 200 Cooling water connection ... DN 15 to 25
Nominal pressure	PN 16 to 400
Operating temper. range	20 to 600°C

Desuperheater CHPR

Description

The CHPR desuperheater (further CHPR only) is device designed for the process steam temperature control. CHPR is equipped with two or more mechanical nozzles with variable flow area. The number of nozzles is designed according to the required power. The amount of injection water is controlled by a separate control valve.

The CHPR serves for precise and economical steam temperature control by a direct injection of cooling water into flow of steam. It is designed primarily for by-pass stations.

Technical data	CHPR
Execution	Desuperheater with radial injection, with weld ends
Diameter nominal range	Steam pipeline connection ... DN 200 to 600 Cooling water connection ... DN 15 to 100
Nominal pressure	PN 16 to 400
Operating temper. range	20 to 600°C

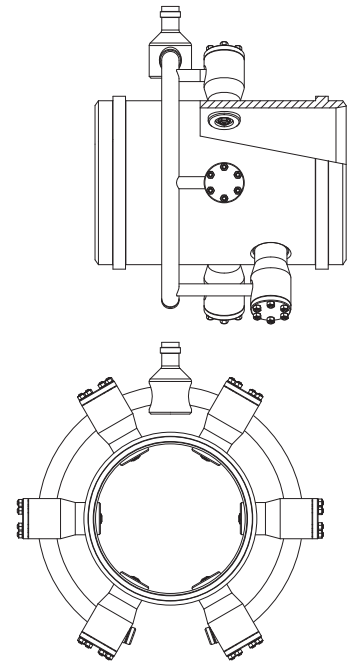

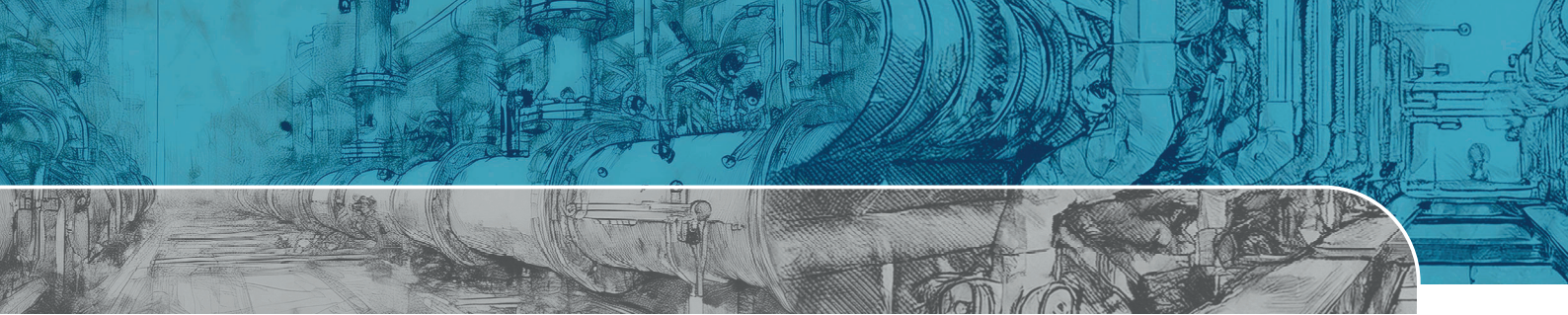

ADDRESS OF FACTORY

LDM, spol. s r.o.
Litomyšlská 1378
560 02 Česká Třebová
Czech Republic
tel.: +420 465 502 511
e-mail: sale@ldm.cz
http: www.ldmvalves.com

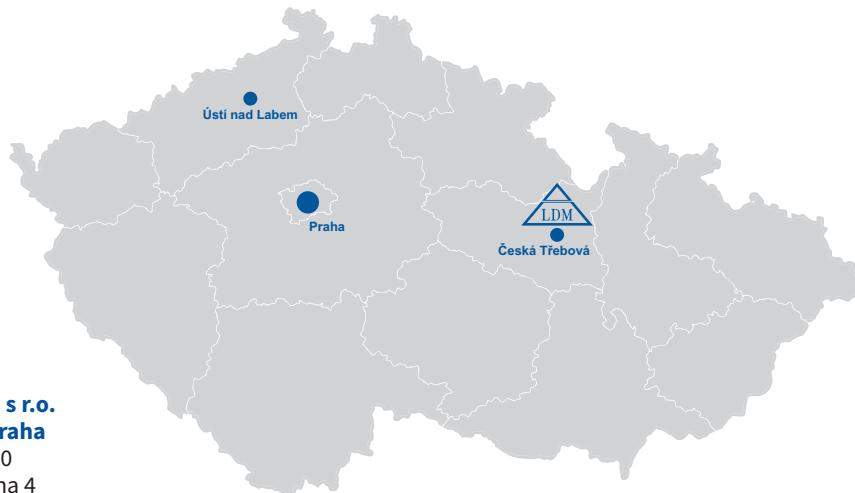

REGIONAL OFFICES

LDM, spol. s r.o.
Office in Ústí nad Labem
Ladova 2548/38
400 11 Ústí nad Labem
Czech Republic
tel.: +420 602 708 257

LDM, spol. s r.o.
Office in Praha
Podolská 50
147 01 Praha 4
Czech Republic
tel.: +420 241 087 360

AUTHORIZED SERVICE CENTRES

LDM servis, spol. s r.o.
Litomyšlská 1378
560 02 Česká Třebová
Czech Republic
tel.: +420 465 502 411-3
e-mail: servis@ldm.cz

Service is also provided LDM subsidiaries abroad

LDM SUBSIDIARIES ABROAD



LDM Bratislava s.r.o.
Mierová 151
821 05 Bratislava
Slovakia
tel.: +421 2 43415027-8
e-mail: ldm@ldm.sk
http://www.ldm.sk

LDM Polska Sp. z o.o.
ul. Bednorza 1
40-384 Katowice
Poland
tel.: +48 32 7305633
GSM: +48 601 354999
e-mail: ldmpolska@ldm.cz

LDM, Bulgaria, OOD
z. k. Mladost 1
bl. 42, floor 12, ap. 57
1784 Sofia
Bulgaria
tel.: +359 2 9746311
e-mail: ldm.bg@ldmvalves.com

TOO "LDM"
Vodokanalnaya 21
101200 Saraň
Kazakhstan
tel.: +7 7212 566936
mobile: +7 701 7383679
e-mail: sale@ldm.kz

OOO "LDM Promarmatura"
Jubilejnyj prospekt,
dom.6a, of. 601
141407 Khimki, Moscow Region
Russian Federation
tel.: +7 495 777 22 38
tel./fax: +7 495 666 22 12
e-mail: inforus@ldmvalves.com

LDM, spol. s r.o. reserves the right to modify or improve the designs and specifications of such products at any time without prior notice.