

LDM, spol s r.o.

Česká Třebová

www.ldmvalves.com

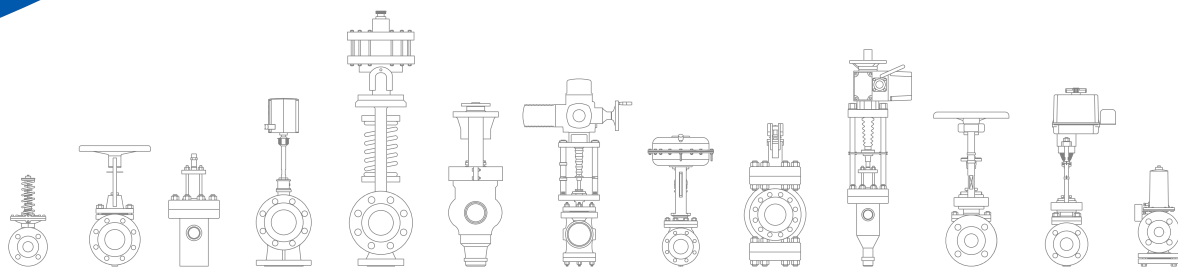

History and present of LDM



- 1909** Birth of the tradition of valves manufacture in Česká Třebová
- 1948** Nationalization
- 1975** Part of the Sigma concern
- 1990** Sigma concern split and privatized
- 1991** Foundation of LDM, spol. s r.o.

1909 - Josef Jindra with his employees



2024 - Manufacturing plant of LDM
in Česká Třebová

LDM in figures

Number of employees: **200**

Number of production workers: **134**

Number of technical staff: **50**

Number of designers: **10**

Senior management: **6**

Plant area: **40.000** m²



Organization chart of LDM

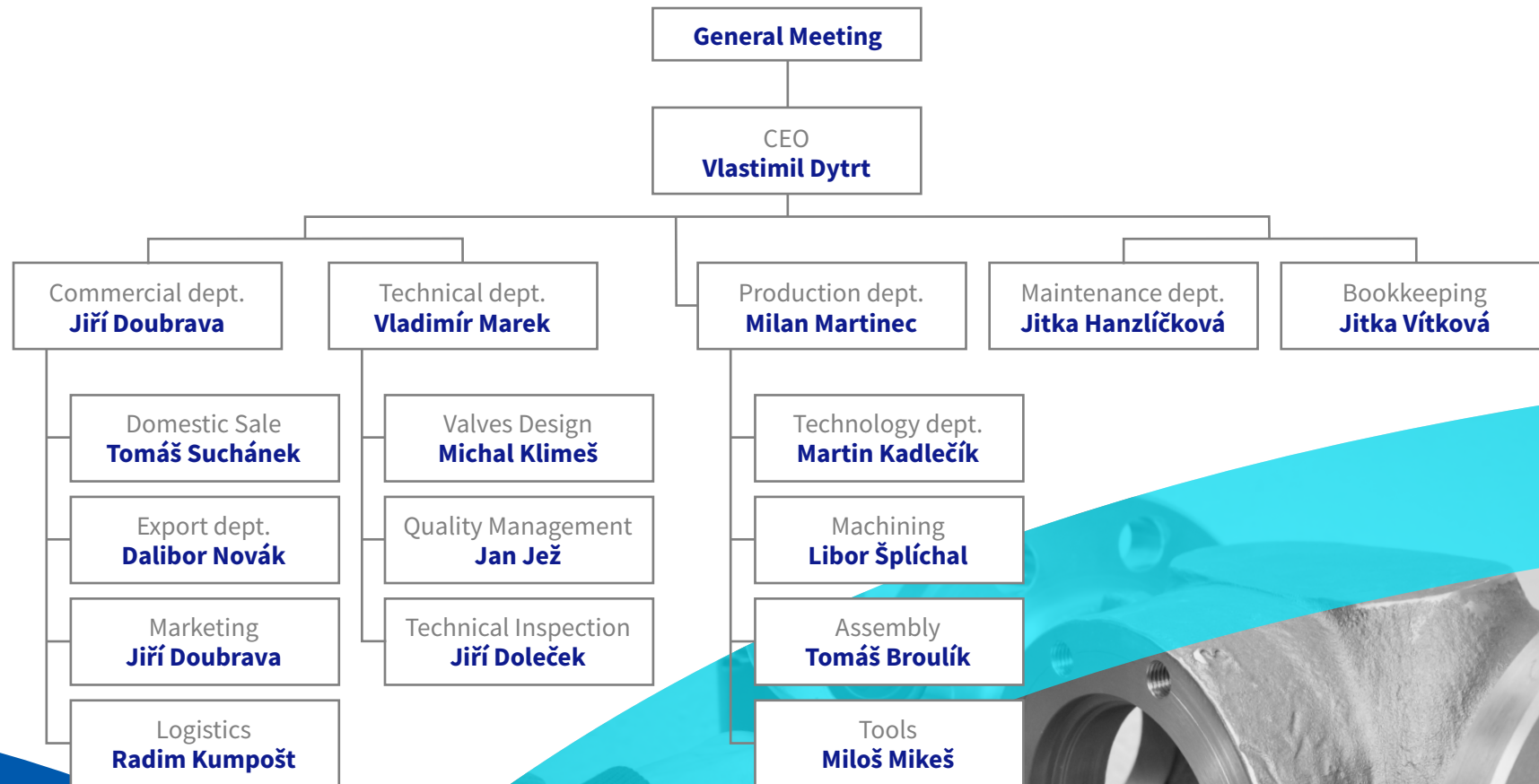

Certificates and approvals



- 1997** Initial certification of the Quality Management System according to ISO 9001, currently being implemented integrated management system according to ISO 9001, ISO 14001 and ISO 45001
- 2023** Recertification of product approvals and welding processes
- 2024** Recertification of a qualified supplier for a nuclear plant energy companies ČEZ and Slovenské elektrárne



Subsidiaries and technical offices

- 1994** LDM Bratislava (Slovakia)
- 1997** LDM Polska (Poland)
- 1997** LDM servis (warranty and post-warranty maintenance and repair)
- 1998** LDM Bulgaria (Bulgaria)
- 1998** technical offices in Prague and Ústí n. Labem
- 2001** LDM Armaturen (Germany)
- 2005** OOO "LDM Promarmatura" (Russia)
- 2008** TOO "LDM" (Kazakhstan)



R&D and production

Valve design with support
of Siemens NX , ANSYS and Fluent

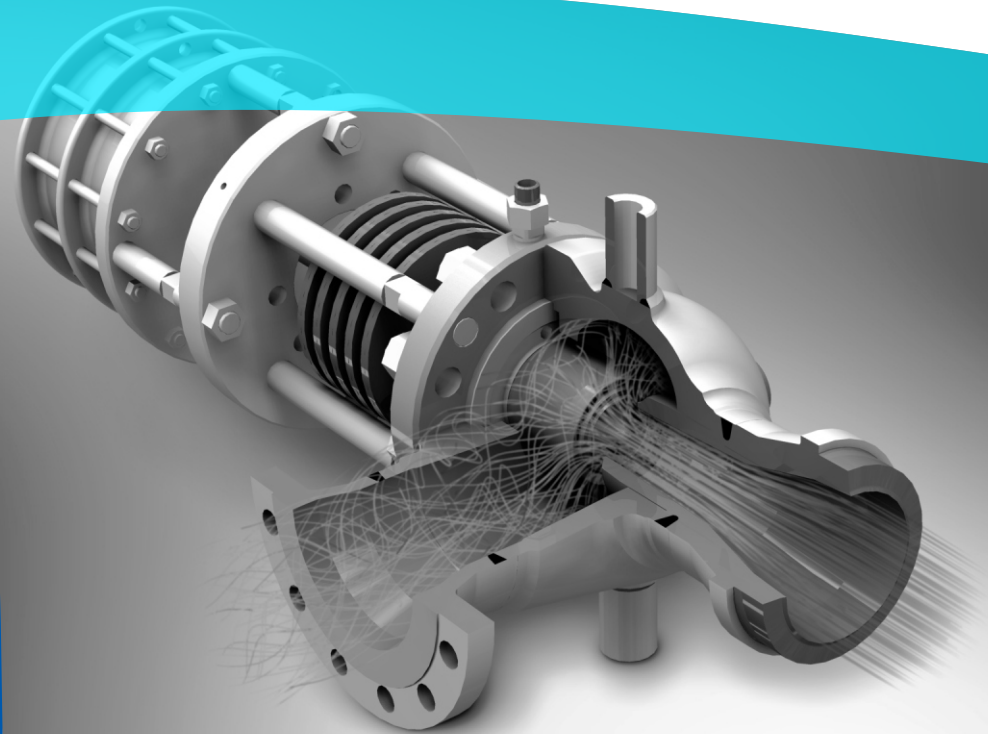
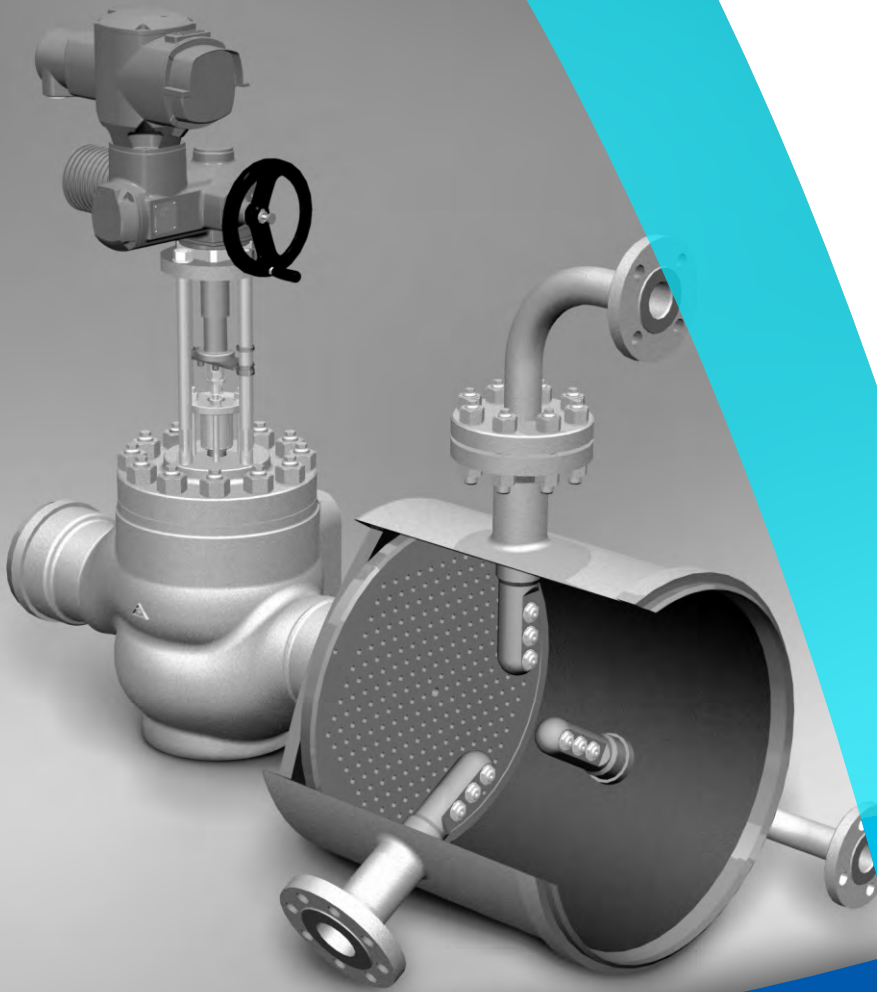

R&D and production



Machining parts on turning and milling machining centres





R&D and production

Heat treatment

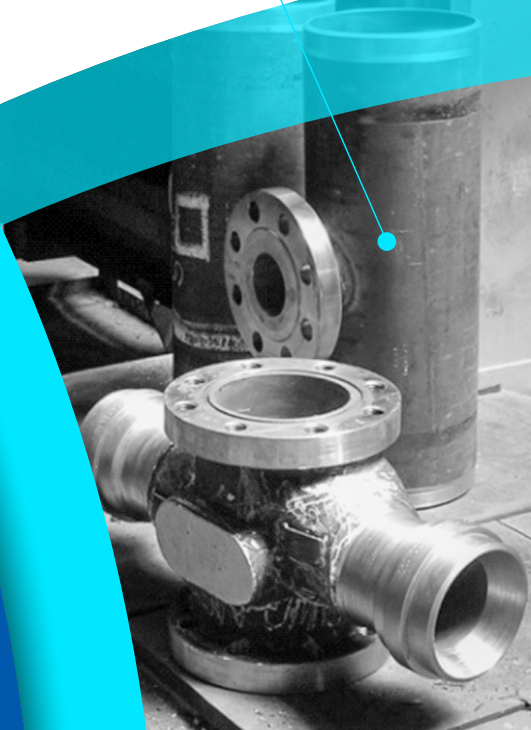

Robot welding of valve seats

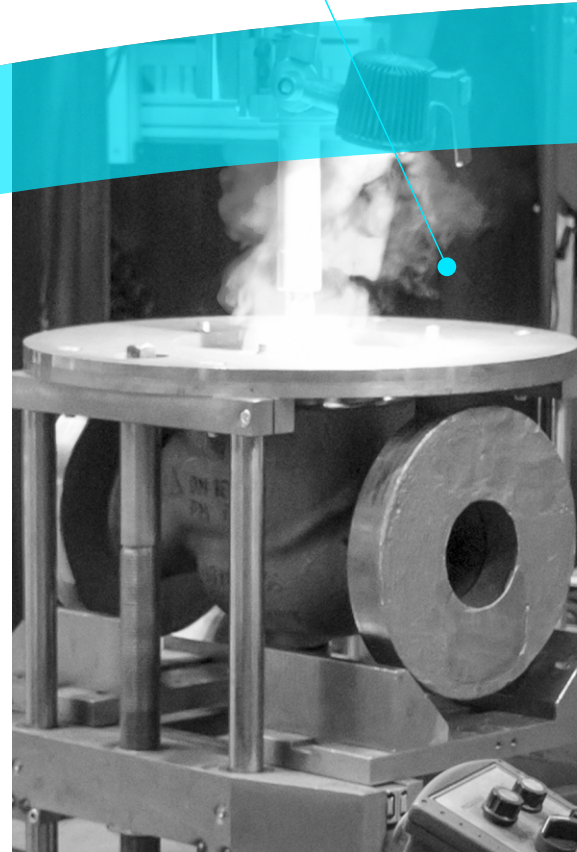

Laser cutting of V-ported plugs

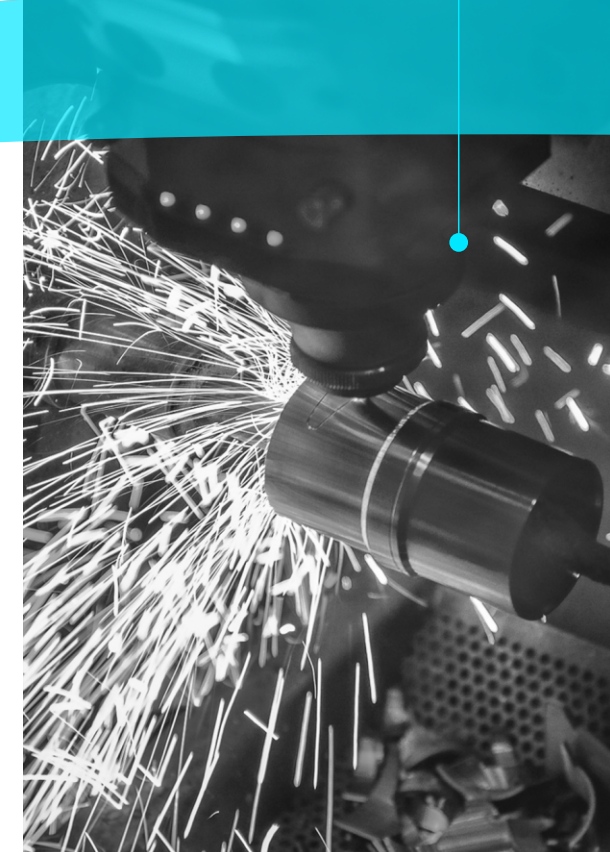

R&D and production



Production management support with APS



Just-in-time valve assembly

100% pressure test of assembled valves



R&D and production

Surface finish coating

- galvanic zinc coating
- chemical nickel-coating
- galvanic tin coating
- cyanide copper coating
- galvanic silver coating

Testing of flow characteristics and Kv values

Lifetime testing



Product portfolio - product segment 01

Valves up to PN 40

- COMAR line
- BEE line
- RV 113
- 200 line
- UV x16
- UV 200
- Check valves

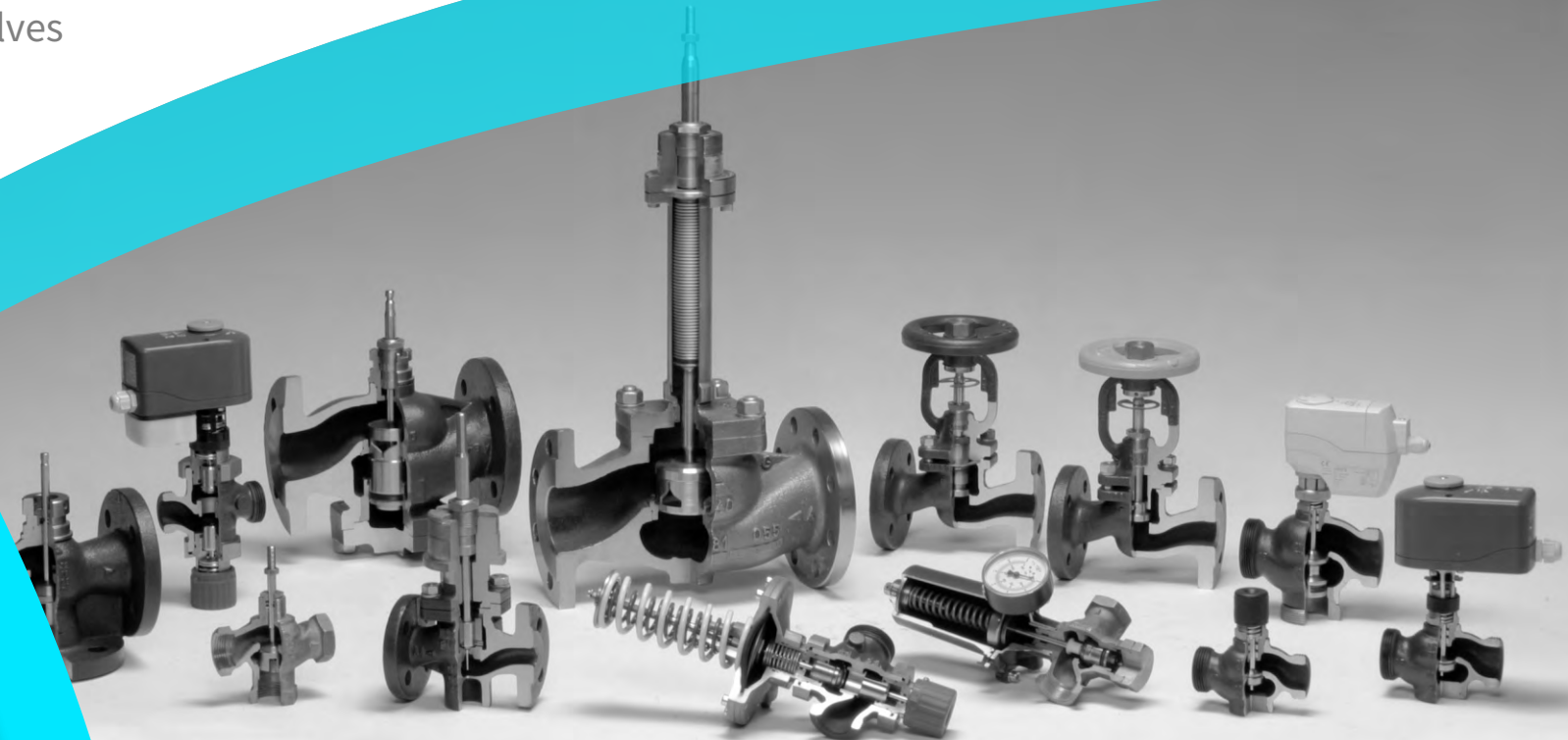

Product portfolio - product segment 02

Valves up to PN 630

- 300 line
- 500 line
- 700 line
- 800 line
- 900 line
- Steam desuperheating
- Series G
- Safety valves
- RK 601
- SU 59

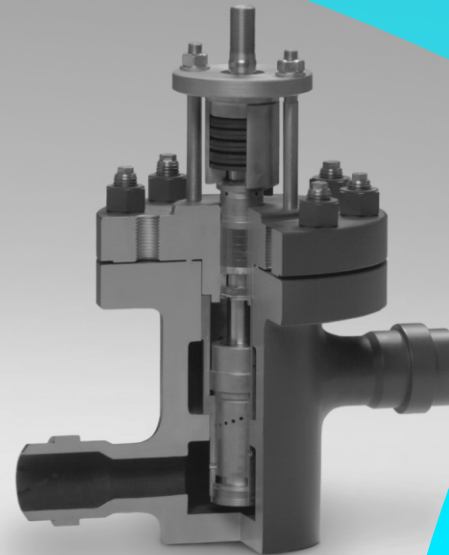
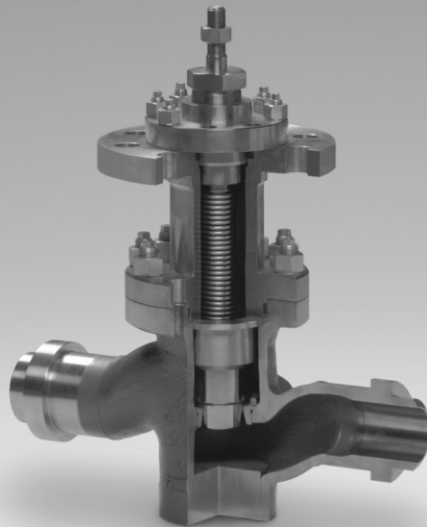

Product portfolio - product segment 03

Valves for Nuclear Power Plants

- A 10
- RV 701 NA
- RV 702 NA
- G 46 NB
- G 47 NB
- PV 1108
- SiZ 1508
- PV 1509
- RP 5330

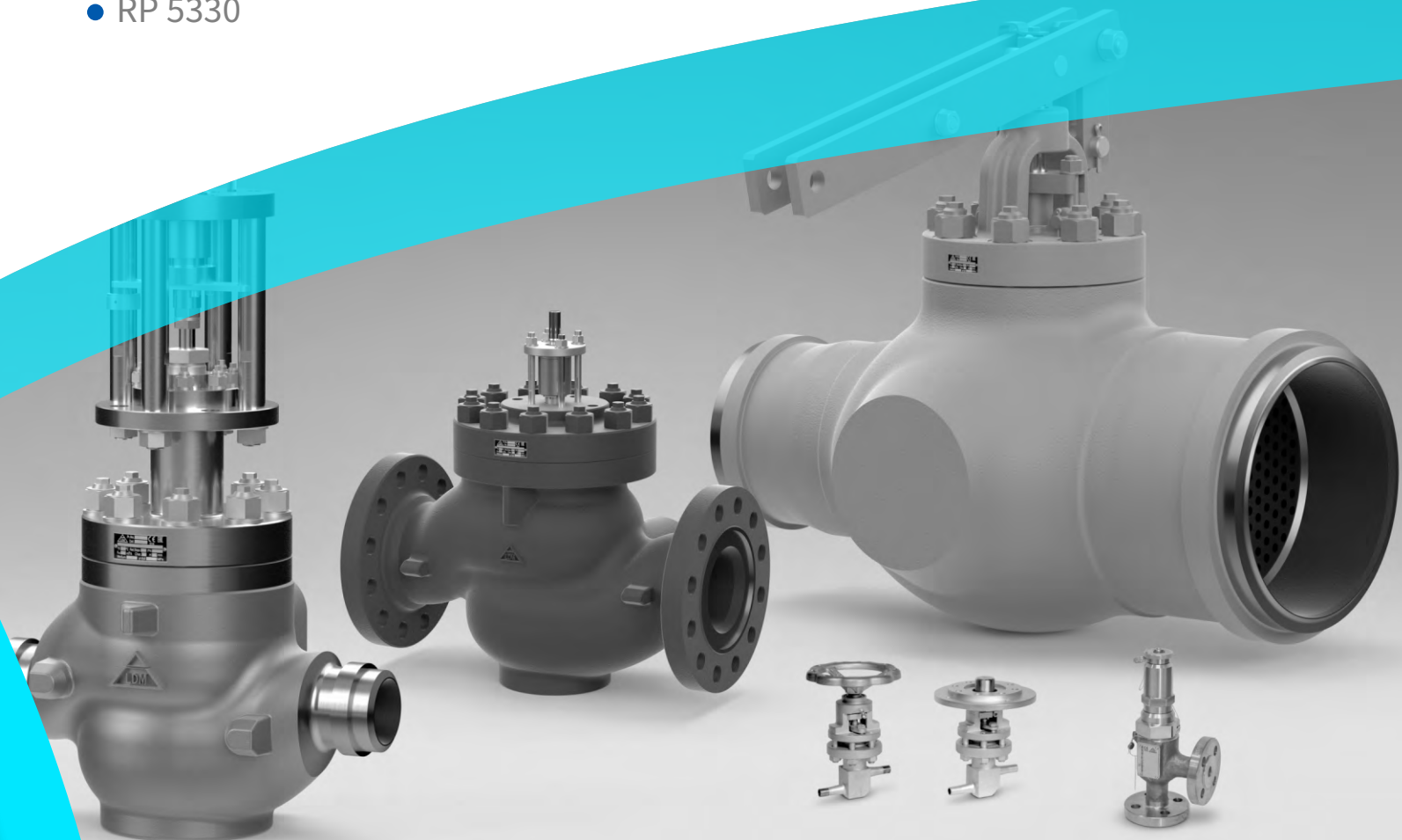



LDM, spol s r.o.

Česká Třebová

www.ldmvalves.com



LDM, spol. s r.o.

Litomyšlská 1378, 560 02 Česká Třebová, Czech Republic

tel.: +420 465 502 511, fax: +420 465 533 101, mail: sale@ldm.cz